

TrueView 435 Hardware User Guide



GeoCue Group, Inc

10/26/2021

Version 1.0.2

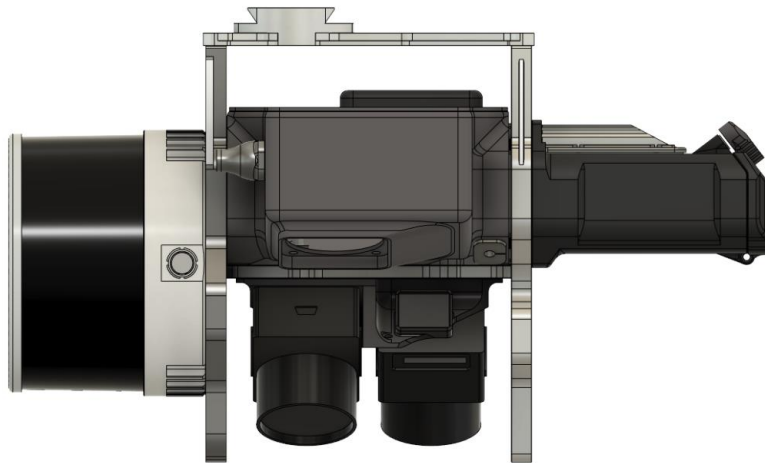

Updated for Firmware Version 3.0.7.1

Contents

About GeoCue Group, Inc.	4
About TrueView® 435	5
A TrueView Cycle	5
TrueView Hardware Integration Kit (M600)	6
Installing the Top Plate and Controller Box	6
Installing the Ronin Mount	10
TrueView Hardware Integration Kit (M300)	12
Installing the Controller Plate, Antenna Mast Base	12
Installing M300 TrueView Mounting Bracket.....	14
TrueView 3DIS Installation	17
TrueView Battery	21
TrueView Data Storage Devices.....	22
UMS	22
Camera SD Cards	22
System Configuration File (SCF).....	22
Core Configuration File (CCF).....	23
CCFSection6 – POS	23
CCFSection8 – Camera.....	24
CCFSection11 – Configuration Laser.....	25
CCFSection15 – Battery.....	26
CCFSection16 - Cycle	27
CCFSection17 – Storage Auto Delete	28
TrueView 435 Field Operations	28
1. Base Station	28
2. Pre-Flight	29
3. Disable Obstacle Avoidance	30
4. Center of Gravity (GC) Calibration	31
5. Controller Box LEDs	32
6. Heading Alignment Maneuver.....	35
7. After Landing	36

TrueView EVO	37
Logging in To APX15.....	37
Configure TrueView Wi-fi.....	37
Log in to APX-15	39
Download To4 Files.....	39
Measuring GNSS Lever Arm Offsets	40
Z Offset.....	41
X Offset.....	42
Y Offset.....	43
TrueView 3DIS/M600 Pro – Mission Checklist	44
Hardware Maintenance.....	45
Dust Filter	45
FAQ	47
Support.....	48

About GeoCue Group, Inc.

GeoCue Group was founded in 2003 by a group of engineers with extensive experience in developing hardware and software solutions for primary remote-sensed data acquisition. Our initial products were aimed at reducing schedule and cost risk in geospatial production workflows by providing organizational, productivity and data management tools for base geospatial data production. These tools have been realized as the GeoCue product family. Today GeoCue workflow management tools are used by a majority of North American geospatial production shops. In 2005, GeoCue began selling and supporting Terrasolid tools for kinematic LIDAR data production. This was followed in 2009 by our acquisition of QCoherent Software LLC, the creator of the point cloud exploitation toolset, LP360. Today GeoCue is the largest supplier of kinematic LIDAR processing tools in North America and LP360 is the world's most widely used tool for exploiting point cloud data. In 2014, GeoCue Group started a division focused on using small Unmanned Aerial Systems for high accuracy mapping. Leveraging our expertise in production, risk reduction, and point cloud processing tools, we are continuing to bring new services and products to market to provide surveyors and other geomatics professionals exciting tools for geospatial data extraction using low cost drones including Loki, our plug-and-play PPK direct positioning system, and now our new TrueView LIDAR/Imagery fusion sensors. To learn more, visit www.geocue.com.

About TrueView® 435

The TrueView® 435 is GeoCue's latest addition to our LIDAR/camera fusion platform designed from the ground up to generate high accuracy 3D colorized LIDAR point clouds. Featuring dual GeoCue Mapping Cameras, Hesai PandarXT-16 laser scanner and Applanix Position and Orientation System (POS), the result is a true 3D imaging sensor (3DIS). With its wide 120° fused field of view, the TrueView 435 provides high efficiency 3D color mapping and will redefine LIDAR wire extraction and dense vegetation penetration applications for all- purpose grade sensors.

A TrueView Cycle

All TrueView sensors write their various data streams to a standard file folder structure called a "Cycle." The original meaning of *cycle* was an on/off cycle of the sensor. It is possible to have multiple collections (flights, in the case of a drone) in a single Cycle, so it is not necessarily correct to think of cycle as being synonymous with a flight.

TrueView Hardware Integration Kit (M600)

The TrueView 3DIS was designed to be used with the GeoCue TrueView Integration kit, which includes an antenna mounting plate and a DJI Ronin gimbal mount with vibration dampeners. If your TrueView 3DIS and M600 were purchased through GeoCue, the antenna mounting plate and Ronin mount were installed by a GeoCue technician. If you purchased your M600 from a third party, you will need to install these components before using your TrueView system. The following steps explain how to install your TrueView integration kit.

Installing the Top Plate and Controller Box

1. To install the top plate and controller box you will need the following components:
 - a. Top plate with antenna mast. (Figure 1)



Figure 1 – Top Plate with Antenna Mast

- b. Controller box without LED Readout (Figure 2) or with LED readout (Figure 3)



Figure 2 – Controller box without readout display



Figure 3 - Controller Box with readout display

- c. Set Screw (4) (Figure 4)



Figure 4 – Set Screws

- d. 50mm Spacer (4) (Figure 5)



Figure 5 - Spacers

- e. Hex Driver – 1.5mm and 2mm (Figure 6)



Figure 6 – Hex Driver

2. On the drone, remove the four screws indicated below (Figure 7). These screws will be used to attach the mounting plate later, so save them for *Step 5*.



Figure 7 – Prepare for mounting

3. Apply Loctite to the four Set Screws and install in the empty screw spaces from *Step 2* using a 1.5mm hex driver (Figure 8). **WARNING** - Do not overtighten. If screws are too tight, they will press into the plastic plate below and could cause the plate to crack.



Figure 8 – Install set screws

4. Install the four 50mm spacers on top of the set screws (Figure 9).



Figure 9 – Install spacers

5. Line the plate up on top of the spacers. Apply Loctite to the four screws removed in *Step 2* (Figure 10) and secure the plate to the top of the spacers (Figure 11).

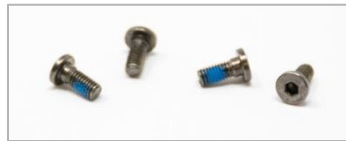

Figure 10 – Loctite the removed screws

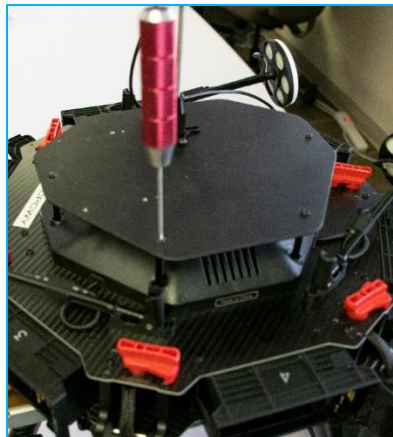

Figure 11 – Install the controller box

6. Install the controller box on to the top plate with the LEDs facing out away from the center of the drone. The controller box is designed to fit into the antenna mounting plate without the need for additional hardware.

Installing the Ronin Mount

1. On the drone, remove the three screws on each leg of the stock mount (Figure 12). Keep the screws, they will be used again.

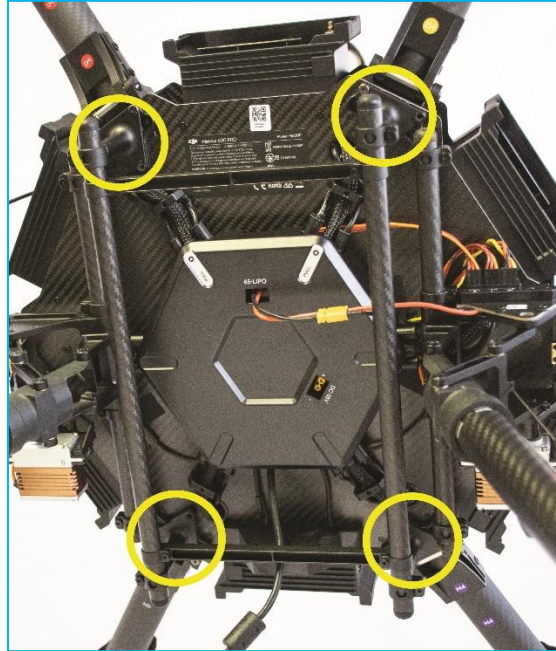

Figure 12 – Remove stock mount screws

2. On the Ronin Mount, loosen the screws that hold the legs to the rails enough so that they can be rotated (Figure 13).

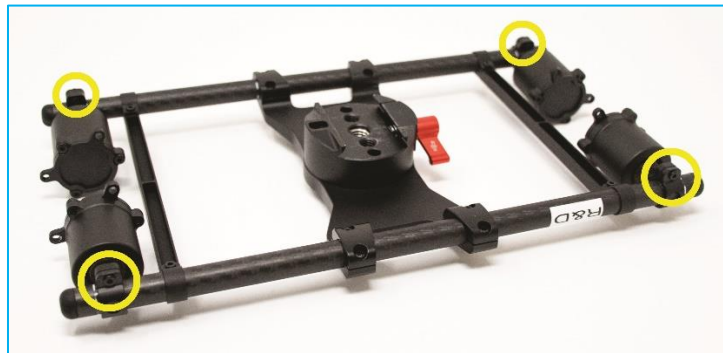

Figure 13 – Loosen leg screws

3. Rotate legs so that the mount stands off the drone (Figure 14).



Figure 14 – Rotate Legs

4. Using the screws removed from the drone in *Step 1*, apply Loctite to each screw and install the mount with the red lever facing the back of the aircraft (Figure 15).

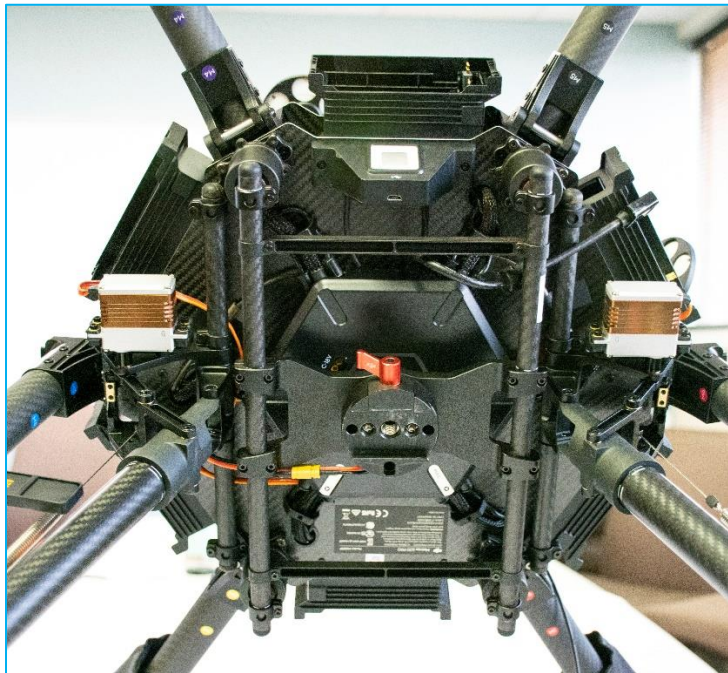

Figure 15 – Install mount

TrueView Hardware Integration Kit (M300)

The TrueView 3DIS was designed to be used with the GeoCue TrueView Integration kit, which includes an antenna mast base and a TrueView mounting bracket for M300 with vibration dampeners. If your TrueView 3DIS and M300 were purchased through GeoCue, the antenna mast base and TrueView mounting bracket were installed by a GeoCue technician. If you purchased your M300 from a third party, you will need to install these components before using your TrueView system. The following steps explain how to install your TrueView integration kit.

Installing the Controller Plate, Antenna Mast Base

1. To install the controller plate and antenna mast base you will need the components listed below.
 - a. (1) Antenna Mast Base ([Figure 16](#))



Figure 16 – Antenna Mast Base

- b. (1) Controller Plate ([Figure 17](#))

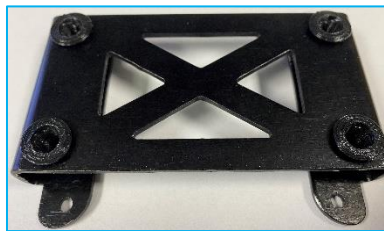

Figure 17 – Controller Plate

- c. Torque screwdriver set to 5.7 Inch-Pounds (INLB) ([Figure 18](#))



Figure 18

- d. Threadlocker – Removeable Blue 242.
- e. (2) M₃ x 0.5 - 8mm length screw
- f. (2) M₃ x 0.5 - 10mm length screw
- g. (2) 4mm Spacer

Apply Threadlocker to all screws and tighten to 5.7 inch pounds. Figure 19 shows the installation diagram.

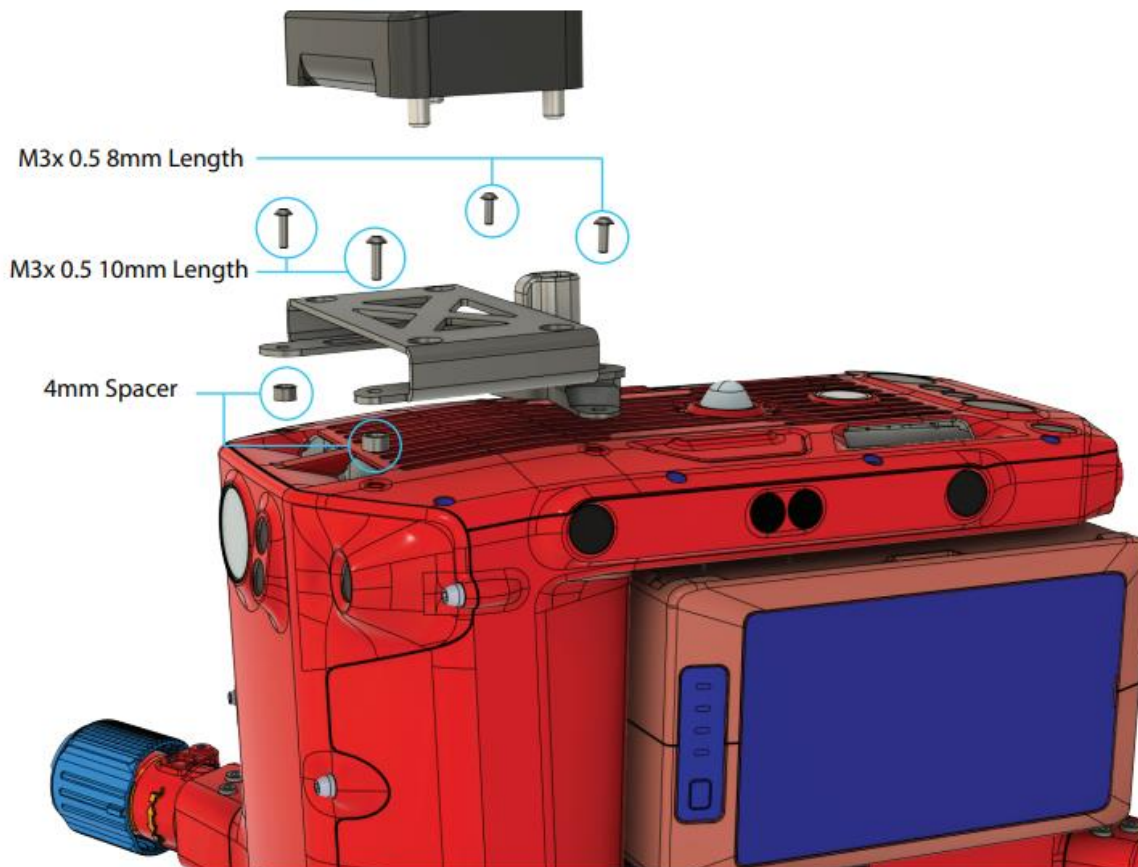

Figure 19

Installing M300 TrueView Mounting Bracket

- i. M300 TrueView mounting bracket (Figure 20) with slanted TPU spacer (Figure 22) attached.

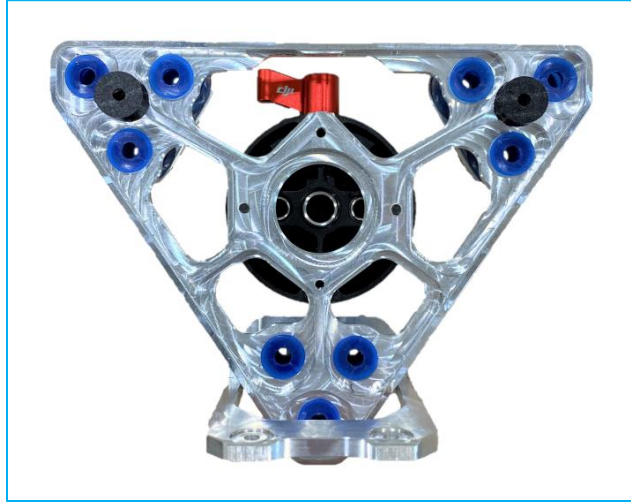

Figure 20 – M300 TrueView bracket

- j. (2) M3 x 0.5 - 10mm length screw
- k. (2) M3 Nylon Washer
- l. (2) M3 x 0.5 – 20mm length screw
- m. (2) Slanted TPU Spacer

1. Invert the drone so the bottom is facing up.
2. Apply threadlocker to the M3 x 0.5 – 10mm length screws and install on the front two hole of the bracket and aircraft body. The M3 nylon washers go between the M300 body and the TrueView bracket (Figure 21). Tighten screws with torque wrench using 5.7 inch-pounds of torque.

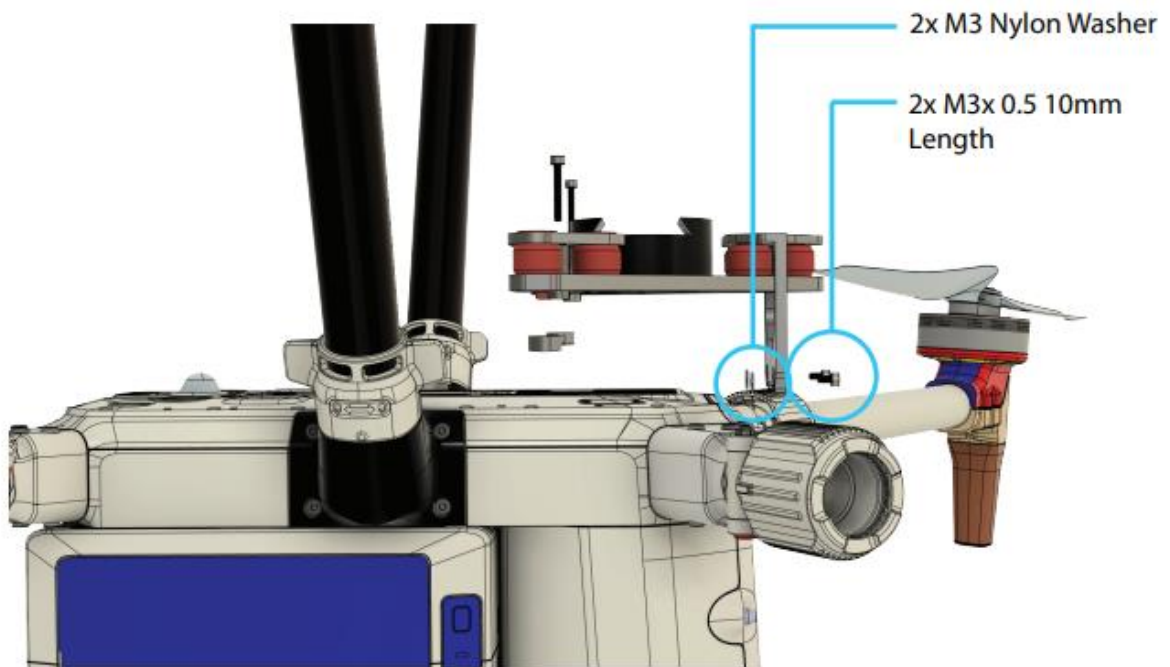

Figure 21

3. Place TPU spacers between the bottom of the aircraft and the TrueView bracket. The angle of the spacers matches the aircraft body (Figure 22).

4. Apply thread locker to the M3 x 0.5 – 20mm screws and install the screw into the TrueView mounting bracket and aircraft body (Figure 22). Tighten screws with torque wrench to 5.7 inch-pounds.

**** Note that the angle of the spacers match the drone body. ****

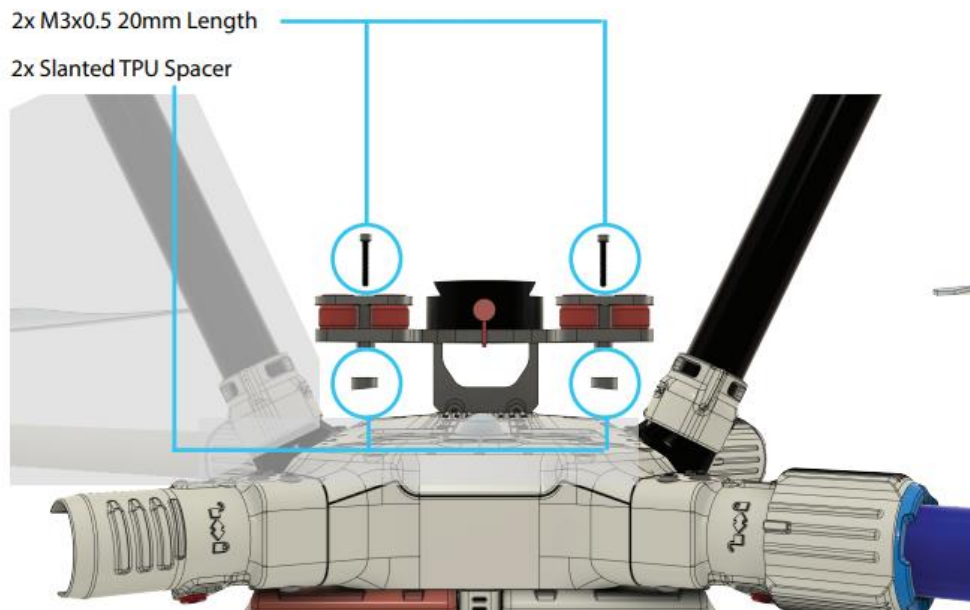

Figure 22

TrueView 3DIS Installation

The TrueView 3DIS mounts using a standard DJI Ronin mount on the DJI M600. The instructions below describe how to install the TrueView 410 on the M600 when you are ready to use the system to collect data.

1. Place the drone on a stable surface with the landing gear down.
2. Turn the red lever (Figure 23) on the Ronin mount until it is loose, but do not remove it completely.

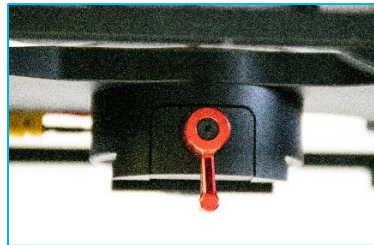

Figure 23 – Ronin mount locking lever

3. Align TrueView so that the battery compartment is facing forward on the drone and the laser scanner is towards the back.
4. From the back of the drone, lift the TrueView up to the mount from the left side and slide the TrueView mount into the Ronin mount (Figure 24). Slide until the TrueView dove tail is in the center of the Ronin mount (Figure 25).



Figure 24 – Ronin mount



Figure 25 – TrueView 410 in Ronin mount

5. Tighten the red lever until the TrueView is tightly locked in place.
6. Loop the safety lanyard through the upper metal plate of the TrueView and around one of the bars of the payload mount and close the safety lanyard (Figure 26).

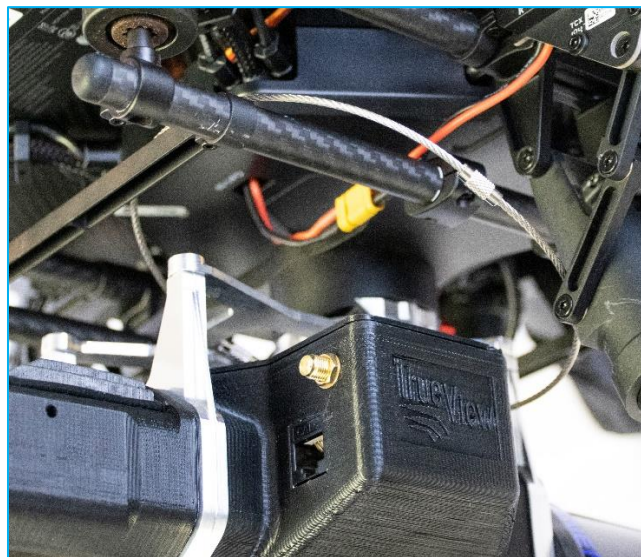

Figure 26 – Safety lanyard

7. Connect the USB or CAT6 cable to the controller box (Figure 27) and route it down to the TrueView unit. Be sure to secure any excess cable but leave enough slack to prevent tension on the connector. The cable type depends on your controller firmware.



Figure 27 – Control box cable

8. Attach the USB or CAT6 cable to the TrueView unit (Figure 28). Be sure to secure any excess cable but leave enough slack to prevent tension on the connector.

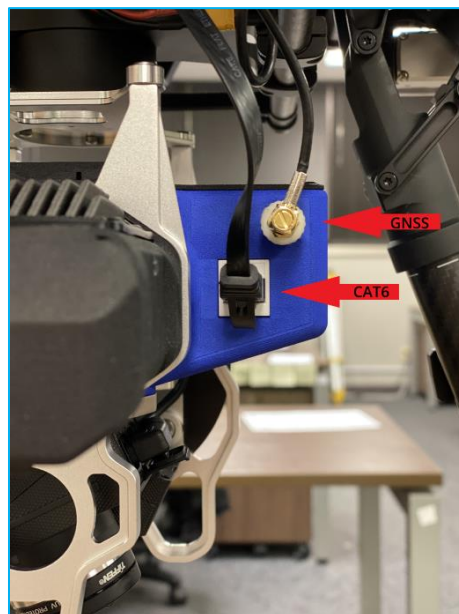

Figure 28 – Control box cable into TrueView

9. Attach the GNSS antenna cable to the TrueView unit (Figure 28) and screw the antenna onto the antenna mount (Figure 29) or insert into the revision 2 antenna mount. **Do not use** the integral mount on the readout controller box if your control box has one as this feature has been deprecated. Be sure to secure any excess cable but leave enough slack to prevent tension on the connector.

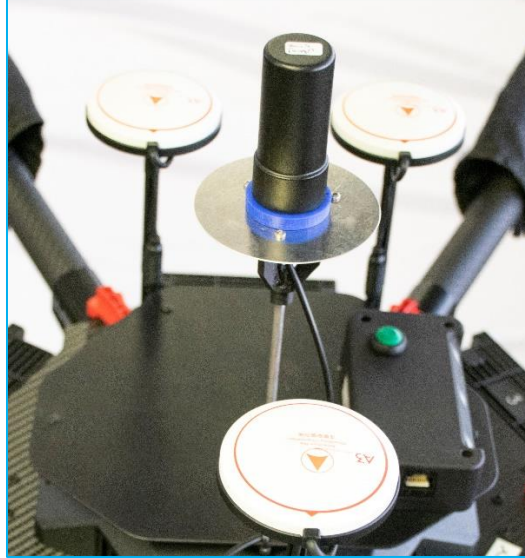

Figure 29 – GNSS antenna

TrueView Battery

The TrueView 3DIS is powered by its own 3200 mAh removable lithium-ion battery. The TrueView power system was designed to be standalone and does not use power from the power system of the aircraft and makes sure that TrueView does not interfere with critical flight functions. You can expect to get about 90 minutes from each battery under normal conditions, but cold temperatures can significantly reduce battery life.



Figure 30 – Removeable battery

The TrueView 3DIS comes with two [RRC2054](#) batteries (Figure 30), which have built-in charge status indicators, and a charging station.

TrueView Data Storage Devices

UMS

The TrueView UMS (USB mass storage) device is the media attached to the TrueView sensor on which A TrueView Cycle will be written during flight operations and system wind-down.



Figure 31 - UMS

The UMS should meet the following requirements to be used on the system.

1. USB-C connection (USB 3.1)
2. Format:
 - a. ExFAT after updating firmware to v3.0.7.1 or later.
 - b. NTFS after updating firmware to v2.0.3 through v3.0.5.2.
 - c. FAT32 format for firmware pre v2.0.3.
3. 114 GB minimum capacity
4. Need "SystemConfiguration.json" and "CoreConfiguration.json" files on the drive during operation.

Camera SD Cards

1. Format:
 - a. 32GB card – FAT32
 - b. 64GB or larger card – ExFAT
2. Minimum recommended read speed: 270 MB/s
3. Minimum recommended write speed: 70 MB/s
4. SD Cards should be formatted using the built-in format option in the CCF for CCU firmware v3.0.7.1 or later with camera firmware v00.72.01. Review [CCF Section 8](#) of this document for instructions to use the built-in format tool.
 - a. The next best formatting option is to use the SD Card Formatter Utility from the SD Association. It is **not** recommended to use the Windows OS formatting utility.

System Configuration File (SCF)

The System Configuration file (SCF), SystemConfiguration.json, must reside on the TrueView USB Mass Storage and is copied into the Cycle\System folder upon creation of each Cycle. The SCF contains information on the calibration parameters of all components for each TrueView system and is used by TrueView EVO to process TrueView data. The latest calibration file for each sensor is stored on the TrueView Reckon portal.

Core Configuration File (CCF)

TrueView System settings are stored internally to the system but can be changed by modifying the CoreConfiguration.json file on the UMS. The system identifies if the file has been modified, then operates accordingly. Features may be turned on or off by using a true or false Boolean in the Core Configuration file. Other fields can be configured with a numeric value, such as the Battery Status Percentage or Proximity Mode Distance.

Note: It is recommended to open and modify the Core Configuration file with [Notepad++](#).

The following sections describe the most common sections of the Core Configuration file that a user may wish to modify.

CCFSection6 – POS

```
"CCFSection6": "Configuration - POS",
"ConfigurePOS": {
  "GNSS_model": 0,
  "GNSS_lever_arm_change": false,
  "GNSS_lever_arm_x": "-0.008",
  "GNSS_lever_arm_y": "0.000",
  "GNSS_lever_arm_z": "-0.443",
  "GNSS_lever_arm_std_dev": "0.100",
  "FTPPushWaitTime": 30
},
```

Figure 32 - Core Configuration - POS

This section is applicable for CCU firmware v2.1.7 and later.

If the "GNSS_lever_arm_change" is *true*, the TrueView is configured to update the lever arms in the APX unit to the values ascribed in this section. A user should only modify "GNSS_lever_arm_x", "GNSS_lever_arm_y", or "GNSS_lever_arm_z" if they are not using the system on a drone integrated by GeoCue. Updating the lever arms using this section of the Core Configuration file replaces the need to log into the APX-15 to update those values. See [Measuring GNSS Lever Arm Offsets](#) in this guide.

The values shown in Figure 32 are the standard TrueView 410 mounted on an M600 with the GNSS antenna secured on the top mounting plate not integral to the control box with an LED readout.

CCFSection8 – Camera

```
"CCFSection8": "Configuration - Camera",
"ConfigureCam": {
  "CameraOperate": true,
  "ExposureModeAvailable": [ "Manual=1", "Auto", "Aperture Priority", "Shutter Priority" ],
  "ExposureMode": 1,
  "ExposureTimeAvailable": [ "1/30 = 0x14D", "...", "1/500 = 0x0014", "1/640 = 0x000F", "1/
  "ExposureTime": 12,
  "FNumberAvailable": [ "1/2.8 = 0x0118", "...", "1/11 = 0x044C" ],
  "FNumber": 560,
  "ISOAvailable": [ "125 = 0x007D", "...", "6400 = 0x1900", "Auto = 0xFFFF" ],
  "ISO": 65535,
  "IsIntervalTimeTrigger": true,
  "TimeInterval": 2000000,
  "CameraFailSafe": false,
  "CameraFileTransferWindDown": true,
  "CameraFileTransferCapture": false,
  "CameraStorageFormat": false,
  "CameraStorageFormatConfirm": false
```

Figure 33 - Core Configuration – Camera

This section is applicable for CCU firmware v2.2.1 and later.

- Set "CameraOperate" to *false* if you do not wish to use the cameras for a mission. For example, a late evening flight.
- If the "CameraFileTransferWindDown" is *true*, the TrueView is configured to operate in Standard mode and the images will get transferred to the UMS drive during the wind-down sequence. **This field is *true* by default and is recommended not to be changed.**
 - If it is *false*, the TrueView is configured to operate in Extended mode and the images will not get transferred during wind-down and they will have to be manually downloaded from each camera SD card and placed in the Camera 1 and Camera 2 folders in the cycle folder.
 - The image transfer process takes about 5 minutes for a 15 minutes flight. For aircraft that can fly for extended periods of time (greater than 30 minutes of flight), it is recommended to set this field to false, and transfer the images manually.
- "CameraStorageFormat" and "CameraStorageFormatConfirm" are used to format the camera SD cards. If both values are set to True, the TrueView system will format the camera SD cards the next time the system is powered on. The TrueView system will set these value back to false after the format is complete. If only one of these values is set to True, the format will not occur.

CCFSection11 – Configuration Laser

```

"CCFSection11": "Configuration - Laser",
"ConfigureLaser": {
  "LidarOperate": true,
  "LIDARTimeOut": 30,
  "IsDistanceStartStopLidar": true,
  "Distance2StartStop": 5,
  "LaserModelAvailable": [ "Quanergy M8 = 0", "Riegl miniVUX= 1", "Pandara = 2"],
  "LaserModel": 0,
  "LIDARInitWait":30,
  "FieldOfViewRange":["Min: 0", "Max: 360"],
  "FieldOfView_low_angle": 120,
  "FieldOfView_high_angle": 240,
  "RieglSettingOnly":"Below is the setting of Riegl Lidar",
  "ScansSpeedAvailable": ["5 Hz = 0","10 Hz = 1","20 Hz = 2"],
  "ScanSpeed": 1,
  "PulseRepetitionRateAvailable": [ "100 kHz = 0", "200 kHz = 1" , "200 kHz (low power)= 2", "300 kHz = 3"],
  "PulseRepetitionRate": 1,
  "AngularStep": 0.093,
  "GPS_EXT_UDP_PORT": 5018,
  "GPS_EXT_EDGE": 0,
  "GPS_EXT_FORMAT": 0,
  "GPS_EXT_SEQUENCE": 0,
  "GPS_MODE": 4,
  "M8SettingOnly":"Below is the setting of Quanergy M8 Lidar",
  "FrameRate":10,
  "BaudRateAvailable":["1200 = 0","...", "9600 = 3","...", "115200 = 7"],
  "BaudRate":3
},

```

Figure 34 - Configuration Laser

This section is applicable for CCU firmware v3.0.5 and later.

Set "LIDAROperate" to *false* if you do not wish to use the laser scanner for a mission. For example, an imagery only mission.

LIDARTimeOut is used to signal via a red SYS light that the laser scanner did not properly start within this time frame. We recommend 30 seconds as the default.

Laser Model must match the scanner being used. A TrueView 410 should be 0, TrueView 600 series should be 1, TrueView 435 should be 2.

The FrameRate should be left as 10 and not be changed.

FieldOfViewRange is informational only and provides the user with the lowest and highest values that can be used for *FieldOfView_low_angle* and *FieldOfView_high_angle*. LIDAR data will only be collected between the low and high angle.

FieldOfView_low_angle is set to 120° by default (Figure 35).

FieldOfView_high_angle is set to 240° by default (Figure 35).

The BaudRate should be left as 3 and not be changed.

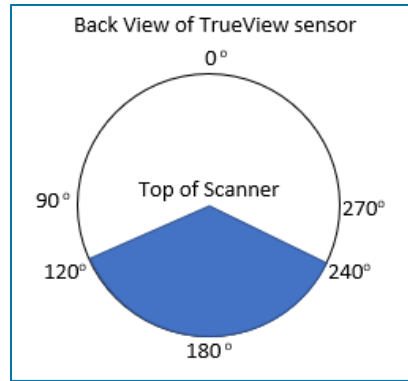

Figure 35 - Field of View

CCFSection15 – Battery

```

"CCFSection15": "Configuration - Battery",
"ConfigureBattery": {
  "LowBatteryPercent": 50,
  "CriticalBatteryPercent": 30
}
    
```

Figure 36 - Core Configuration - Battery

This section is applicable for CCU firmware v1.2.3 and later.

The Battery Status Light (BAT) on the TrueView controller box will be colored based on the percentage entered in the “LowBatteryPercent” and “CriticalBatteryPercent” fields. The BAT light will be green if the battery is above the “LowBatteryPercent” value. **It is 50 by default.** The BAT light will be yellow if the battery is between the “LowBatteryPercent” and the “CriticalBatteryPercent” value. The BAT light will be red if it is below the “CriticalBatteryPercent” value. **It is 30 by default.**



Figure 37

CCFSection16 - Cycle

Section 16 of the Core Configuration file determines if Proximity Mode is active, and how Proximity Mode will operate. This section is applicable for CCU firmware v2.0.x and later.

```

"CCFSection16": "Configuration - Cycle",
"ConfigureCycle": {
  "ProximityMode": true,
  "ProximityDistance": 25,
  "ProximityAutoStop": true
},

```

Figure 38 - Core Configuration - Cycle

If "ProximityMode" is *true* (**default and highly recommended**), proximity mode is active, and a home point is created within the sensor where it was powered on. The SYS light will flash green when the system is ready to take off. It will automatically start recording data when the sensor travels more than the "ProximityDistance" (in meters X, Y and Z) from the home point.



Figure 39 - Controller Box SYS LED

If "ProximityMode" is *false*, proximity mode is disabled. The SYS light will turn solid yellow when the system is ready to start recording. The user must press and hold the green button on the controller box until the SYS light turns solid green, indicating the system is recording data and ready for takeoff.

"ProximityAutoStop" determines if the system will automatically begin wind-down when the sensors enter the "ProximityDistance" (X, Y and Z) from the home point.

If "ProximityAutoStop" is *true*, the system will automatically begin wind-down and start transferring files to the UMS drive when the sensor is within the "ProximityDistance" (X, Y, and Z).

The SYS light will be flashing yellow when the aircraft lands. Wait until the SYS light is solid yellow (file transfer complete) to power off the system.

If the system has not landed within the "ProximityDistance" or the SYS light is still solid green after landing, the user must press and hold the green button on the controller box until the SYS light starts flashing yellow. Wait until the SYS light is solid yellow before powering off the system.

If "ProximityAutoStop" is *false*, the system will not start wind-down until the user presses and holds the green button on the controller box and the SYS lights starts flashing yellow. Wait until the SYS light is solid yellow before powering off the system.

CCFSection17 – Storage Auto Delete

```
"CCFSection17": "Configuration - Storage Auto Delete",  
"ConfigureStorageAutoDelete": {  
  "AutoDelete": true,  
  "FreeSpaceLowThresholdPercent": 20,  
  "FreeSpaceHighThresholdPercent": 80  
}
```

Figure 40 - Configuration - Storage Auto Delete

This section is applicable for CCU firmware v2.o.x and later.

If "AutoDelete" is *true* (**default**), TrueView automatically deletes data from the UMS or camera SD cards when the storage percentage reaches the "FreeSpaceHighThresholdPercent". Folders will be deleted until the "FreeSpaceLowThresholdPercent" is reached. Older files will be deleted first.

If "AutoDelete" is *false*, the user must manually delete data from the UMS or SD cards. **If storage space is full, flight data will not be stored.**

TrueView 435 Field Operations

1. Base Station

The TrueView 3DIS records GNSS signals during flight which will be corrected later in EVO. This type of system is known as a PPK system. Base station processing methods should be considered during the planning process because the user will need to determine how they plan to correct their flight data before collecting. TrueView GNSS signals can be corrected by one of three methods:

1. **Single base** – Single base, as the name implies, is a static recording from one single base station which is close in proximity to the flight area. Corrections are computed at the base station, then applied to the data collected by TrueView. CORS stations can also be used for single base processing if they are within 12 miles of the flight area and record static data at 1Hz. The base station must also record both L1 and L2 signals and must be during the same time as the flight. Single base is the only processing method if you plan to process with the [local](#) option selected.
2. **SmartBase** – SmartBase is a cloud processing option that uses multiple CORS stations to compute base corrections for your flight. Smart base processing allows for longer baselines from the flight area and the user does not have to setup a base station or download CORS data from a nearby station. This option still requires an existing CORS network in the area of flight.

Users can go online to the [Applanix SmartBase website](https://www.applanix.com/smartbase/) and determine if their flight location is covered by the SmartBase network and estimate the quality of the results.

3. **PP-RTX** – PP-RTX is a cloud processing option that does not require a base station or CORS network. PP-RTX corrections can be computed anywhere. Accuracy is reduced using this method but can be used as a last resort option in the event of base station failure or lack of CORS network.

More information can be found in our knowledge base articles:

<https://support.geocue.com/positioning-options-in-true-view-workflows/>

<https://support.geocue.com/single-base-vs-smartbase-vs-pp-rtx>

2. Pre-Flight

1. Ready the drone for flight and insert the battery into the TrueView unit (Figure 41).



Figure 41 – Insert TrueView Battery

2. Lift all antennas up and if using the foldable GNSS TrueView antenna, tighten the nut (Figure 42). If using the square tubing mast, insert the mast into the mast port and press until firmly seated.

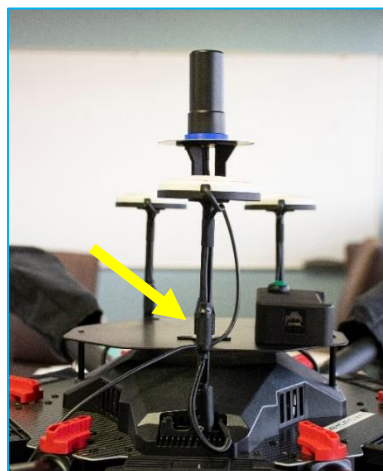

Figure 42 – TrueView Antenna

3. Place the drone in an open area where you intend to takeoff. TrueView will need an unobstructed view of the sky. Avoid placing the drone near large metal objects such as buildings or vehicles to avoid signal disturbance.
4. Insert the USB drive.

VERY IMPORTANT
MAKE SURE THAT ALL CABLES ARE SECURED TO
PREVENT CONTACT WITH PROPS DURING FLIGHT.

5. Turn on the TrueView unit with the switch located in the battery compartment (Figure 43).



Figure 43 – TrueView Power Switch

6. Close the battery compartment door and lock the latch.
7. The TrueView will now cycle through the power up procedures.

3. Disable Obstacle Avoidance

IMPORTANT M300 Only

The integration of the TrueView 3DIS system will cause disruption to the M300's built-in obstacle avoidance detection systems. If these systems are not disabled, they can cause erratic and potentially dangerous behavior including loss of control of the drone. To disable obstacle avoidance, perform the following steps:

1. Launch the DJI Pilot application, open a mission, or go into manual view.
2. Tap the Ellipsis menu (...) on the top right corner of the screen.
3. Tap the second icon from the top Obstacle Sensing Settings.
4. Tap each tab for Horizontal, Upward, and Downward tap the toggle button off for each category. (Figure 44)

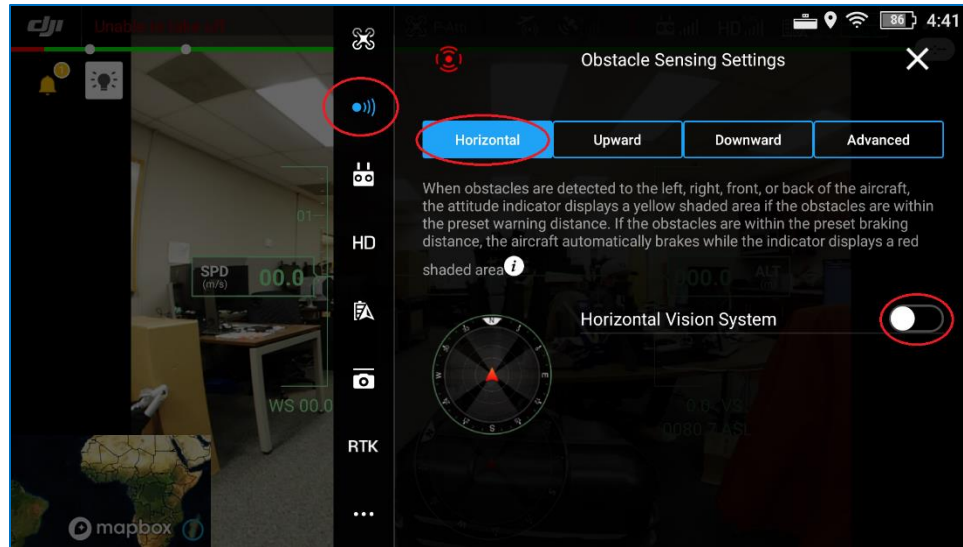

Figure 44 – DJI Pilot, Obstacle Sensing Settings Menu

4. Center of Gravity (GC) Calibration

IMPORTANT M300 Only

When heavy payloads are carried on the M300 platform a center of gravity (GC) calibration must be performed there is any change to the payload. This would include if you switched from a TrueView 410 to a TrueView 435 or DJI P1 or even switch to flying without a payload. The aircraft must be in flight and hovering to start the calibration. It is ideal to perform this calibration in a wind free environment. To perform the GC calibration, perform the following steps:

1. Launch the DJI Pilot application, open a mission, or go into the manual view.
2. Tap the Ellipsis menu (...) on the top right corner of the screen.
3. Stay within the Flight Controller Settings tab and scroll to the bottom of this screen.
4. Tap the Center of Gravity Auto Calibration Button and follow the instructions. (Figure 45)

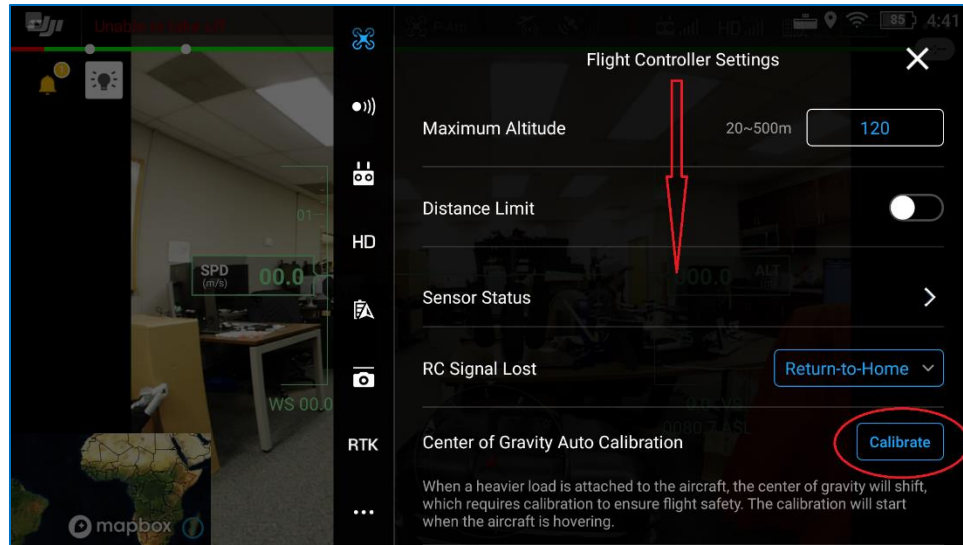

Figure 45 – DJI Pilot, Flight Controller Settings Menu

5. Controller Box LEDs

8. When the power switch is turned on, the system will go through its startup procedure and all lights (Figure 46) on the controller box will flash yellow. After a few seconds, each LED light will begin to show a sequence of colors indicating status.
 - a. BAT: Flashes until the battery percentage is known, then turns a solid color.
 - i. Green LED indicates battery is above 50%.
 - ii. Yellow LED indicates battery is between 30 and 50%.
 - iii. Red LED indicates battery is below 30%.
 - b. GNSS: This LED will flash yellow until GNSS signal is received, then turn solid green.
 - c. SYS: The system light will flash yellow until the system is ready for operation. When the system is ready, it will begin flashing green if proximity mode is active.
 - i. Proximity mode is a feature added in firmware version 2.0.3. When the system is powered on, its position is recorded, and this position is used as the home point for the system. Once the sensor travels a specified distance (25 meters by default) from the home point, the system automatically begins recording data. This feature can be disabled by setting the "ProximityMode" flag to false in the Core Configuration file on the UMS. If the feature is disabled, you will have to manually start recording data by pressing and holding the green button until the SYS light turns solid green.



Figure 46

9. When the SYS LED is flashing green, this means the proximity mode is active and you are ready for takeoff.
 - a. If proximity mode was disabled by the user, wait for a solid yellow SYS light then press and hold the green button until the SYS light turns solid green.
10. Turn the drone and transmitter on and connect to the drone on the iPad.
11. Arm the drone and take off and climb to the mission altitude.
12. Once the system travels 25 meters from takeoff (X,Y, and Z), it will begin recording data.

Figure 47 shows all the lighting sequences, LED messages, and their meanings. Figure 48 shows how to interpret the symbols in the table.

BAT	GNSS	SYS	LED Readout	Meaning
			GeoCue – True View	True View initializing ...
			Firmware Updating	Updating firmware for True View...
			Firmware Updated	Firmware updated successfully.
			Battery Check	True View checking battery.
			Insert UMS, Press Cycle	True View cannot recognize the UMS. Plug in/re-seat the UMS and press the Cycle button.
			Battery: _%	Battery Level.
			UMS Mounted	UMS is mounted and recognized by the True View.
			Copying Old File	During initialization, if the system detects incomplete Cycles in the internal memory it will download them to the UMS and attempt to combine with any related Cycles found in the root of the UMS. Cycle the system after the wind-down completes.
			Init. GNSS...	Checking GNSS signal. Battery light indicates battery level (Green= 50% or more; Yellow= 30-50%; Red= less than 30%)
			GNSS Ready	GNSS has initialized, ready to set location.
			Getting Location	True View is setting location.
			Location Set	True View location is set.
			Init. Cameras	True View checking cameras.
			Cameras Ready	True View cameras are ready.
			Init. LIDAR	True View is connecting to LIDAR.
			LIDAR Connected	True View has connected to LIDAR, LIDAR starting.
			LIDAR Ready	LIDAR has started.
			"Proximity Mode" – "Battery: <number>%" or "Press Cycle" – "then Fly..."	After booting process complete and before sensor takes off, number of satellites has dropped below 4
			"Proximity Mode" – "Battery: <number>%" or "Press Cycle" – "then Fly..."	After booting process complete and before sensor takes off, GNSS signal lost
			Collecting Data	True View is collecting data.
			Wind Down: Closing Connects	Sensor is shutting down hardware components. It is also collecting information to write into CycleParams.json
			Copying Images Progress: _%	True View is copying images to UMS, do not turn system off.
			Flight Complete	Wind down complete, ready to turn off.
			Proximity Mode	Proximity mode active, ready for takeoff.
			Recording Data Stop: Press Cycle	Proximity mode override, True View collecting data, ready for takeoff.
			Wind-down... Closing Connections	After sensor reaches a specific distance from taking off, completely lost GNSS signal (cannot parse NMEA string) when landing
			Wind-down... Closing Connections	After sensor reaches a specific distance from taking off, lost GNSS signal or the number of satellites dropped below 4 at some point during the Cycle, but got it back before landing
			Hard Fault	True View detected a hard error, either with cameras or with other hardware. Need to turn system off.
			Hard Fault	True View detected an issue with the cameras, check if camera memory cards are installed.
			UMS Missing	During wind-down, if the system detects the UMS is missing, plug in/re-seat the UMS and press the Cycle button or turn off the sensor.

Figure 47 – Controller Box LEDs

Pattern	Description
	LED Off
	Solid LED – Can be green, yellow, red, or white.
	Flashing LED – Can be green, yellow, or red.

Figure 48 – Controller BOX LED Legend

6. Heading Alignment Maneuver

The heading alignment maneuver needs to be done after takeoff, before flying the mission, and after the mission prior to landing for each flight. This maneuver is critical for getting accurate heading corrections for the IMU and will impact the results of the data if not performed.

1. Before takeoff, identify a safe direction to perform the heading alignment maneuver. Avoid areas with people, bodies of water, and obstacles.
2. After takeoff, once at mission altitude, let the drone hover in place for two seconds.
3. Push the right stick all the way forward quickly and hold until the drone accelerates to 10m/s. This should take about four seconds. Do not provide any other input. The drone should be accelerating in a straight line.
4. After reaching 10m/s, about four seconds of forward flight, release the stick and leave it centered. The drone will quickly stop. **Note: Speeds beyond 12-14 m/s may yield poorer results.**
5. Wait two seconds, then use the left stick to turn (yaw) the aircraft about 15-20 degrees, then wait a second. (This is for safety; it is intended to prevent the drone from returning directly overhead when you do step 5. Yaw the drone in a direction so that its return path will be clear of people below, and when it returns, it will be at least 15-20m away, and in front of you.)
6. Pull the right stick all the way back quickly and hold until the drone accelerates to 10m/s. This should take about four seconds. Do not provide any other input. The drone should be accelerating in a straight line backwards.
7. After reaching 10m/s, about four seconds of backward flight release the stick and leave it centered. The drone will quickly stop. Wait at least two seconds after it stops before starting the mission. **Note: Speeds beyond 12-14 m/s may yield poorer results.**
8. Fly the mission you have planned.
9. At the end of the mission allow the drone to return to home, but do not let it descend, a final heading alignment maneuver needs to be done.
10. To take back manual control over the drone.
11. Repeat steps 1-6 again. Make sure that when repeating step 4) that you turn the drone sufficiently that it will be several meters (>5) away from the takeoff location at the end of its backwards travel. This is needed so that when returning automatically, the drone will properly navigate to above the takeoff location before beginning its automatic descent. If you are closer than 5m, it will begin descending without aligning with the original takeoff location
12. After the drone has been stationary for two seconds, hold the (Home) button to begin the automatic return and landing. Watch the drone carefully to be certain it is landing in the intended spot. Otherwise, make the necessary adjustments or take manual control to complete a safe landing.

NOTE: On windy days, avoid starting the maneuver into a headwind, as the drone may not be able to achieve high enough accelerations. Try doing the maneuver crosswind if possible.

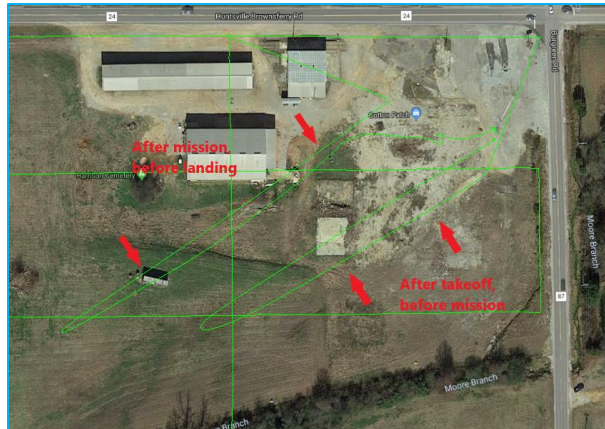

Figure 49 - Heading Alignment Maneuver

7. After Landing

1. After landing the SYS LED should be flashing yellow, indicating the system is transferring data. Do not power off the system during this time or it will interrupt the data transfer.
 - a. If proximity mode is disabled or the aircraft does not land within 25 meters of the home point, the SYS LED will be solid green after landing. Press and hold the green button on the TrueView controller box until the system LED changes from solid green to flashing yellow.
2. The flashing yellow light indicates the TrueView is writing data to the USB drive. Be sure not to power off the TrueView or remove the USB drive during this period.
3. When the system LED changes to solid yellow, the flight data has been transferred to the USB drive.
4. Power off the TrueView with the power switch in the battery compartment.
5. For missions requiring multiple flights, repeat these steps from the “pre-flight” section of this document. The system should be completely powered off between flights (battery swaps) after the data has been successfully written.
6. Check the data for errors before leaving the field.
7. Field check the data to verify all data has been collected. The Field check instructions can be found in the [TrueView EVO Users Guide](#).

TrueView EVO

TrueView Evo is a 64-bit Windows® desktop application used for processing and exploiting TrueView sensor data. It is GeoCue's LP360 point cloud exploitation product with the addition of a collection of tools for TrueView sensor data workflows. Currently, TrueView Evo is available in two licensing levels:

- TrueView Evo – This is equivalent to [LP360 Advanced](#) with the addition of the TrueView workflow tools. It is limited to product areas of no more than 4 km² of LIDAR data
- TrueView Evo Unlimited – this is the same functionally as TrueView EVO but the size limit is removed.

TrueView EVO is the software used to post-process your raw flight data. EVO will generate a 3D LIDAR point cloud in LAS format, colorize the point cloud, geotag the images collected, etc... It is based on GeoCue's LIDAR point cloud exploitation software, LP360, and comes with all the [same tools as LP360 Advanced](#). Tools such as accuracy assessment, automatic and manual ground classification, and contour/ surface exporting.

See the [TrueView EVO User Guide](#) for more information.

Logging in To APX15

It may be necessary to log in to the APX-15 to change settings such as lever arm offsets, or other settings if advised by GeoCue Group Support. The instructions below explain how to configure the TrueView Wi-Fi network and connect to the APX-15. Note that for firmware version 3.0.5 and higher, Wi-Fi is disabled by default. To turn Wi-Fi on, unplug the UMS drive from TrueView, then power on the TrueView system.

Configure TrueView Wi-fi

1. Unplug the UMS from the TrueView 435.
2. Power on the TrueView 435 and wait for 30 seconds, or until "Trueview435" appears in your list of Wi-Fi networks.
 - a. If you cannot find the network, turn off the TrueView 435, connect the UMS to laptop and delete the file "TV_hostapd.conf"
3. If this network exists, connect to it with password "TrueView435."
4. Click Properties (Figure 50) of the TrueView435 Network

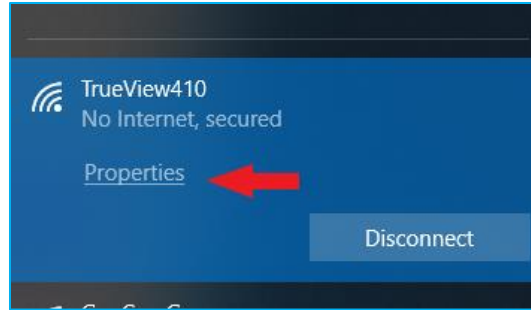

Figure 50 – TrueView435 WiFi network

5. Scroll down to “IP Settings” and click edit.
6. Change setting to “Manual”.
7. Turn on IPv4.
8. Set the following settings (Figure 51):

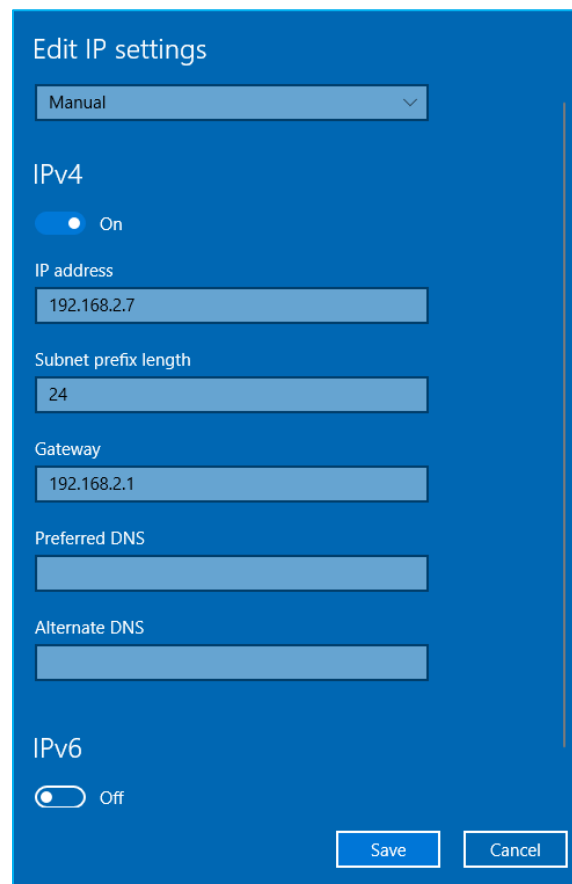

Figure 51 – IP Settings

9. Click save. You may need to restart your computer after making these changes.
10. You should now be able to connect to the APX-15.

Log in to APX-15

The instructions below explain how log in to the APX-15. Be sure the TrueView Wi-Fi has been previously configured before attempting to connect to the APX-15.

1. Power on the TrueView 435 and wait for 30 seconds.
2. Connect to Trueview435 Wi-Fi network.
 - a. If the TrueView435 Wi-Fi network has not been configured on your machine, see [Configure TrueView Wi-fi](#).
3. Open a web browser (Google chrome, Explorer, Edge, etc.)
4. Enter 192.168.2.160 into the address bar.
 - a. When Applanix screen is visible, enter username and password and press enter.
 - i. UN: admin
 - ii. PW: password
5. You should now be logged in to the APX-15.

Download To4 Files

1. After you Log in to APX-15, on the left side menu select **Data Logging -> Data Files -> Internal**
2. Select the applicable To4 file(s). To4 files are named YYYYMMDDHHMM.To4.
3. Select Download Selected Files.
4. Place the To4 file in the system folder of the corresponding cycle.

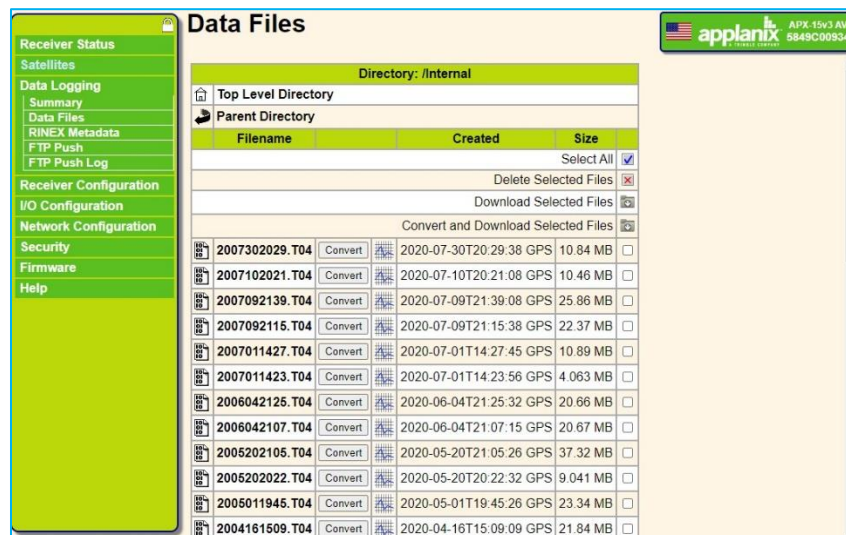

Figure 52 - APX Data Files

Measuring GNSS Lever Arm Offsets

To accurately position your LIDAR data, the position from the GNSS antenna must be transferred to the onboard positioning system. This is done by using lever arm offsets. If your system is mounted on an M600 with the GeoCue integration kit, the offsets have been preset by a GeoCue technician and should not need to be modified. If you are not using the GeoCue integration kit, or are installing the TrueView on a different aircraft, you will need to measure the offsets, [then log in](#) and enter them into the APX-15 (Figure 53), or use [CCFSection6 – POS](#) to update the values in the APX using the Core Configuration file (CCF).

The position is referenced to the APX-15, which is enclosed inside of the housing and cannot be physically measured to. Therefore, you must measure to a physical point on the TrueView frame, then add or subtract offsets to the APX-15. The instructions below explain the physical reference points to measure to, and the offsets between those points and the APX-15.

An assumption is made that the TrueView sensor will be aligned with the heading of the aircraft, and the aircraft will fly forward during data collection. The TrueView battery compartment is the front of the LIDAR sensor, so it should face the heading (front of aircraft).

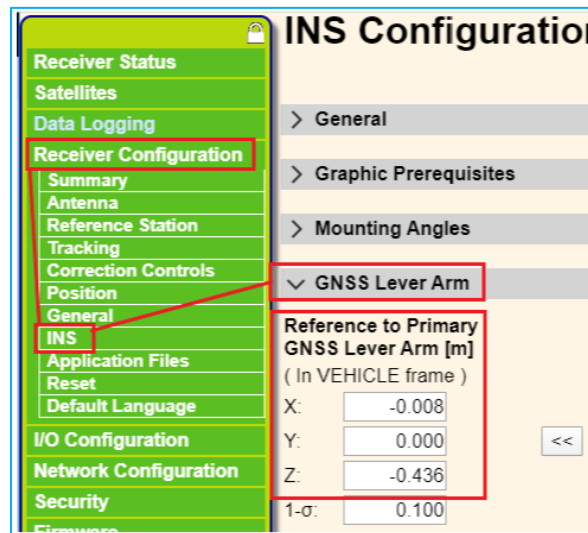

Figure 53 – GNSS Lever Arm

Z Offset

The Z offset is the distance from the APX-15 to the GNSS antenna phase center in the up/down direction. If the GNSS antenna is above the APX-15, the offset is negative. If the antenna is below the APX-15, the offset is positive. The reference point for Z will be the top of the bottom aluminum mounting plate (Figure 54) where the cameras are attached. The APX-15 is 1.644cm above this plate.

A tip for measuring Z is to install the TrueView and GNSS antenna on the aircraft and place it on a table. Measure from the bottom of the antenna (Figure 55) to the table, then add 3.7cm to this measurement. 3.7cm is the offset from antenna phase center to the bottom of the antenna. Then measure up from the table to the aluminum plate. Subtract the distance from the table to the plate, then subtract 1.644cm to get the distance from antenna phase center to the APX-15.

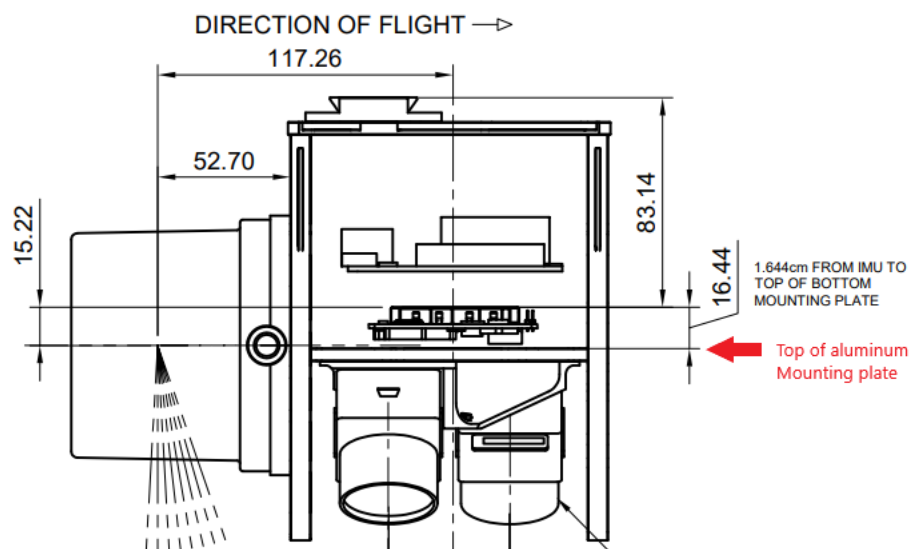

Figure 54 – TrueView 435 measurements



Figure 55 – Bottom of GNSS antenna

X Offset

The X offset is the distance from the APX-15 to the GNSS antenna, in the direction of the heading of the aircraft. If the antenna is forward of the APX 15, the X offset is positive. If the antenna is behind the APX-15, the offset is negative. The reference point is the rear aluminum mounting plate (Figure 56). Measure to the reference point and add or subtract 6.456cm to the offset to get the measurement from your antenna to the APX-15.

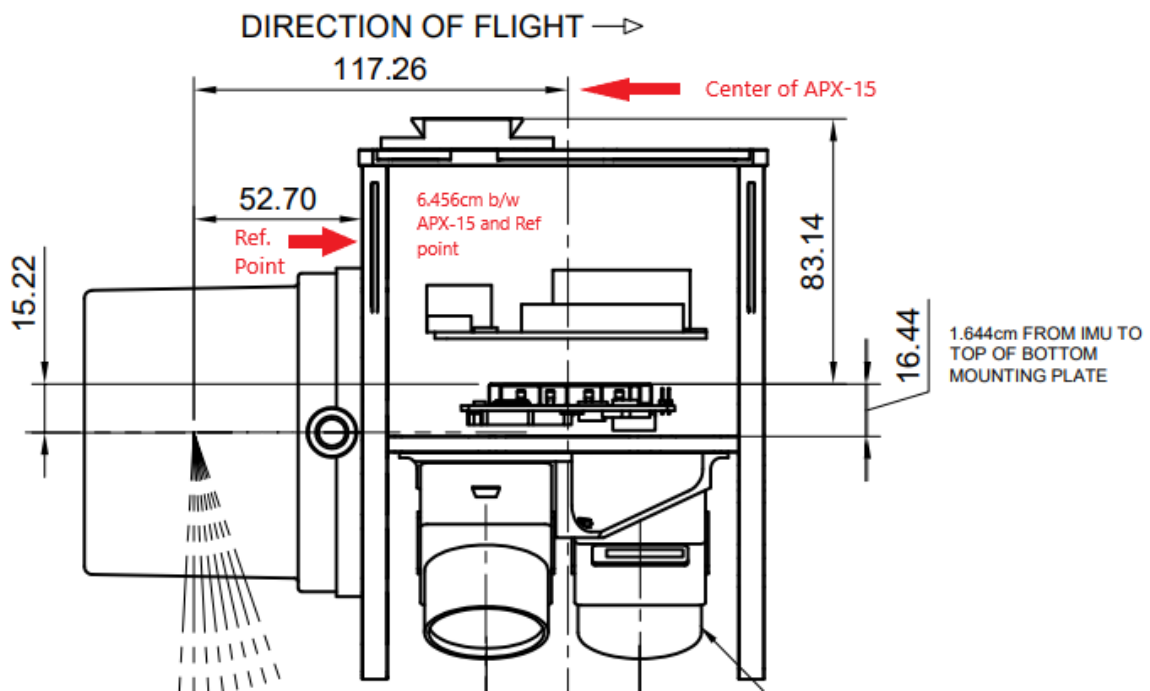

Figure 56 – True View 435 measurements

Y Offset

The Y offset is the distance from the APX-15 to the GNSS antenna, perpendicular to the heading of the aircraft. If you are standing behind the aircraft looking in the direction of the heading, the offset will be negative if the antenna is left of the centerline of the APX-15. The offset will be positive if the antenna is to the right of the centerline of the APX-15. The APX-15 is aligned with the centerline of the TrueView 435 aluminum mounting frame (Figure 57).

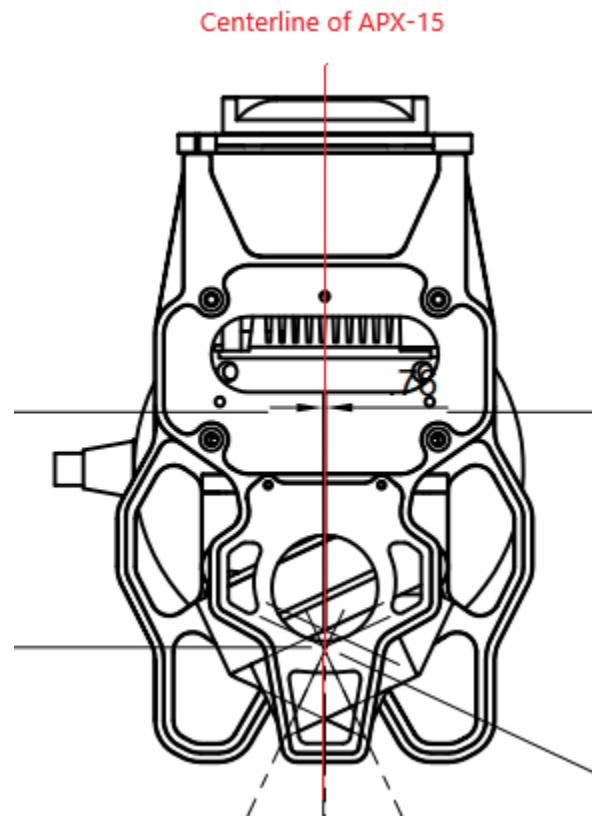

Figure 57 – APX-15 centerline



TrueView 3DIS/M600 Pro – Mission Checklist

Step	Action	Notes
1.	Setup base station and turn ON.	
2.	Check mission plan; modify if necessary.	
3.	Complete a safety briefing and flight plan review with field crew.	
4.	Install TrueView on drone mount. Lidar “top hat” at the back.	
5.	Verify Ronin red lever is fully tightened.	
6.	Verify safety cable attached between TrueView and drone rails.	
7.	Install fully charged TrueView battery pack. Do <u>not</u> turn the unit ON.	
8.	Check all drone GPS antennas upright and secured.	
9.	Verify TrueView CAT 6 and antenna cables are plugged into the unit and Controller box.	
10.	Verify parachute attached and set to locked position and attach clips.	
11.	Verify the TrueView UMS memory stick is inserted.	
12.	Move drone/TrueView to take-off location.	
13.	Unfold and secure drone arms, lock in place.	
14.	Unfold drone propellers, visually inspecting for any problems.	
15.	Install fully charged drone batteries. Do <u>not</u> turn the unit ON.	
16.	Double-check all cabling is secure and does not interfere with the props.	
17.	Remove TrueView lens caps; clean lenses/sensor if necessary.	
18.	Power on TrueView using main power button located just above the battery pack (door must be open to toggle).	
19.	Monitor the TrueView Controller status lights waiting for: <ul style="list-style-type: none"> 1. PWR - Solid Green/Yellow/Red 2. GNSS - Solid Green – Valid date/time stamp received. 3. SYS – Flashing Green - TrueView has initialized, ready for takeoff. 	
20.	Turn on drone controller then power on the drone as per normal operations.	
21.	Wait for drone to initialize and verify there are no errors showing.	
22.	Parachute LED is solid blue (If Applicable)	
23.	Safety Check: Area clear of individuals and flight space is clear to fly.	
24.	Manually take-off and ascend to mission altitude. Verify good LOS to drone and planned flight area.	
25.	Manually preform IMU in-air heading alignment maneuver.	
26.	Initiate mission via flight planning tool.	
27.	Monitor drone/TrueView during flight as per normal operations.	
28.	Upon completion of last flight line in the mission plan, allow the drone to start the Return to Home sequence, but do not let it descend at the Home point. Toggle drone to manual control (P->A->P) instead.	
29.	Manually preform IMU in-air heading alignment maneuver again.	
30.	Make sure the landing area is still clear; complete the landing using Return to Home or manually as preferred.	
31.	After landing, turn off drone.	
32.	Verify SYS light is flashing yellow (transferring data).	
33.	Monitor the TrueView SYS LED; flashing Yellow means data is being copied to USM; solid Yellow data copy is complete. Wait for solid Yellow.	
34.	Power TrueView OFF using main power switch in battery compartment (door must be open to toggle). Never power OFF while SYS LED is still blinking indicating a copy operation is in progress; data loss will occur.	
35.	Remove USM memory stick and pass to post-processing.	

Hardware Maintenance

Dust Filter

Your TrueView 3DIS has a built-in fan to help to cool the internal processors. A filter is needed to prevent dust from entering the system and this filter will need to be changed periodically. A spare filter is included with your sensor spare parts. The steps below explain how to change this filter.

1. First locate the dust cover on your sensor. For TrueView 400 and 500 series, the dust cover is located on top of the sensor, beneath the aluminum mounting frame (Figure 58). For TrueView 600 Series, the dust cover is located on the front of the sensor above the battery compartment (Figure 59)



Figure 58 - TrueView 400/500 Series



Figure 59 - TrueView 600 Series

2. Remove the dust cover by placing the thumb on the thumb indentation (Figure 60) of the dust cover, apply upward pressure, then lift out to remove.



Figure 60

3. Remove the old filter from the dust cover.
4. Replace the old filter with a new filter (Figure 61).
 - a. It is advised to replace this filter with a new filter, but it can be washed and used again if you are in immediate need. Be sure it is completely dry before re-installing. **Do not use a wet filter or moisture could be pulled in by the fan and cause damage to the processors.**



Figure 61

5. Re-Install the dust cover.

FAQ

- **Question** – What is the max distance I can setup my base station from the Flight area?

Answer – It is recommended that the base station be within 20 kilometers (12 miles) of the flight area. It is very important for the base to be in an open flat area if possible. Placing the base station close to buildings, trees, or vertical relief can cause issues with PPK processing and accuracy. The base station should be configured to record at 1Hz.

- **Question** - What are the base station requirements for the TrueView 3DIS?

Answer - The minimum requirement base station must include:

- Static observations recorded to some media
- Dual frequency L1/L2
- Ability to transform the observation file to the RINEX format

- **Question** - Which GNSS Constellations are used by the TrueView 3DIS?

Answer - The Position and Orientation System (POS) and supplied GNSS antenna simultaneously supports:

- (NAVSTAR) Global Positioning System (GPS - USA)
- GLONASS (Russia)
- BeiDou (China)
- Galileo (European Union)

Support

Our searchable support knowledge base contains information on workflows, tips, hints, and probable resolutions to error messages or commonly encountered situations.

<https://support.geocue.com/>

Normal support business hours are **Monday - Friday, 8 AM — 5 PM** USA Central Time.

Our [GeoCue Support website](#) contains general workflow information, in addition to specific issue and error messages that you may encounter. Click on the link and search for information contained in the knowledge base.

If a support request is sent during business hours a representative will typically get back to you within 4 hours. If received after hours, a response will be sent the following day. To speed response time please include the following information in your request:

- Contact information - please include e-mail address and phone number
- Company name
- Product name and version number
- TrueView Model and Serial Number

If your request includes problems pertaining to a specific error message, please include a screen shot of the error message.

For hardware and software support contact: support@geocue.com