

GeoCue  
1/27/2023  
Version 1.1

# TrueView 515vB Hardware Users Guide

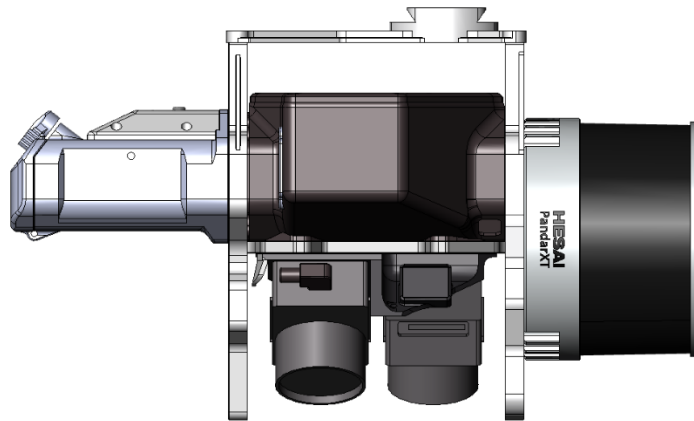

Compatible with LP360 version 2022.1.48 and newer.

## TABLE OF CONTENTS

Version History .....	2
About GeoCue .....	3
About LP360 Drone.....	4
About TrueView Reckon .....	5
A TrueView Cycle .....	6
System Configuration File (SCF).....	6
FCC and IC compliance.....	7
Notice to users.....	8
Warnings.....	8
Disposal .....	9
Overview.....	10
System items .....	10
Product Specifications .....	10
Technical Specifications.....	11
TrueView Hardware Integration Kit (M600) .....	12
Installing the Top Plate .....	12
Installing the Ronin Mount .....	15
TrueView Hardware Integration Kit (M300).....	17
Installing the Antenna Mast Base.....	17
Installing M300 TrueView Mounting Bracket.....	19
TrueView 3DIS Installation.....	22
TrueView Battery.....	25
TrueView External Power Adapter .....	26
Trueview Data Storage Devices .....	27
UMS.....	27
Firmware Update .....	28
Trueview 515vB Field Operations.....	29
Base Station.....	29
Pre-Flight.....	30
Disable Obstacle Avoidance.....	32



Center of Gravity (GC) Calibration..... 33

LED Lights ..... 35

Takeoff Preparation ..... 37

Multifunction Button..... 37

Heading Alignment Maneuver ..... 38

After Landing ..... 40

Debug Port and Cable ..... 41

Lever Arm Adjustment..... 42

Measuring GNSS Lever Arm Offsets ..... 43

    Z Offset..... 44

    X Offset..... 45

    Y Offset..... 46

TrueView Mission Checklist ..... 47

Hardware Maintenance..... 48

    Dust Filter ..... 48

FAQ ..... 49

Support..... 50

List of Tables..... 51

List of Figures ..... 51



## ABOUT GEOCUE

GeoCue was founded in 2003 by a group of engineers with extensive experience in developing hardware and software solutions for primary remote-sensed data acquisition. Our initial products were aimed at reducing schedule and cost risk in geospatial production workflows by providing organizational, productivity and data management tools for base geospatial data production. These tools have been realized as the GeoCue product family. Today GeoCue workflow management tools are used by a majority of North American geospatial production shops. In 2005, GeoCue began selling and supporting Terrasolid tools for kinematic LiDAR data production. This was followed in 2009 by our acquisition of QCoherent Software LLC, the creator of the point cloud exploitation toolset, LP360. Today GeoCue is the largest supplier of kinematic LiDAR processing tools in North America and LP360 is the world's most widely used tool for exploiting point cloud data. In 2014, GeoCue started a division focused on using small Unmanned Aerial Systems for high accuracy mapping. Leveraging our expertise in production, risk reduction, and point cloud processing tools, we are continuing to bring new services and products to market to provide surveyors and other geomatics professionals exciting tools for geospatial data extraction using low-cost drones including Loki, our plug-and-play PPK direct positioning system, and now our TrueView LiDAR/Imagery fusion (3DIS) sensors. To learn more, visit [www.geocue.com](http://www.geocue.com).



## ABOUT LP360 DRONE

LP360 is a 64-bit Windows® desktop application used for many years by the LP360 Geospatial community for processing traditional aerial, mobile, and terrestrial tripod laser scanner data. The LP360 Drone community is the focus of this Users Guide containing the LP360 workflows for processing and exploiting TrueView, microdrones® and guest sensor drone data. Formerly called TrueView EVO, LP360 Drone, is GeoCue's [LP360 point cloud exploitation product](#) with the addition of a collection of tools and workflows for processing drone data. LP360 Drone is the software used to post-process your raw flight data to generate a 3D LiDAR point cloud in LAS format, colorize the point cloud, and geotag the images collected. [LP360 also has many tools for assessing and processing point cloud data](#), such as accuracy assessment, automatic and manual ground classification, and contour/ surface generation. LP360 Drone is available in the following licensing levels:

- **LPViewer** – A free viewer level of LP360 for viewing a point cloud.
- **TrueView EVO/LP360 Drone Explorer** – A low-cost inspector license equivalent to [LP360 Viewer](#), with Image Explorer enabled for viewing True Pose® photos, and Import TrueView Cycle for field QC checks. This is also the license that should be purchased for delivery with [LP360 Explorer Packages](#) provided to end users so they can make full use of the TrueView 3DIS point cloud and photos, plus any derivative products you generate for them.
- **LP360 Drone** – Enables PPK processing for guest systems, such as the DJI P4RTK plus TrueView 2DIS and 3DIS. This is the next generation [ASPSuite Advanced](#) and is equivalent to [LP360 Standard](#) with the addition of the TrueView workflow tools and tools for ground classification and volumetric computations. It is limited to product areas of no more than 10 km<sup>2</sup> of LAS data. Available as an annual subscription or a perpetual license.
- **LP360 Drone+Fast Photo** – Enables local Fast Orthomapping at a lower resolution, local Orthomapping processing if you have your own Metashape license, and Cloud based Orthomapping (using TrueView points). Available as an annual subscription or a perpetual license.
- **LP360 Drone+Cloud Photo 3000** – Enables local Fast Orthomapping, local Orthomapping processing if you have your own Metashape license, and Cloud based Orthomapping (includes 3000 photos per month, additional photos may be processed using TrueView points). Available as an annual subscription or a perpetual license.
- **LP360 Drone+Strip Align** – Enables Strip Align tools for adjusting for dynamic trajectory errors in the dataset. Available as an annual subscription or a perpetual license.
- **LP360 Drone+Business Intelligence Tools** – Enables specific point cloud tasks designed for extraction of non-ground features, such as rail, power lines, buildings, trees. Available as an annual subscription or a perpetual license.
- **LP360 Drone+Unlimited** – this is the same functionally as LP360 Drone with the size limit removed. Available as an annual subscription or a perpetual license.



The legacy TrueView EVO license levels are:

- **TrueView EVO, formerly named TrueView EVO Lite** – Enables PPK processing for guest systems, such as the DJI P4RTK. This is the next generation ASPSuite Advanced and is equivalent to LP360 Advanced with the addition of the TrueView workflow tools. It is limited to product areas of no more than 10 km<sup>2</sup> of LAS data.
- **TrueView EVO 3DIS, formerly named TrueView EVO** – This is equivalent to LP360 Advanced with the addition of the TrueView workflow tools. It is limited to product areas of no more than 10 km<sup>2</sup> of LAS data.
- **TrueView EVO Unlimited** – this is the same functionally as TrueView EVO with the size limit removed. Available as an annual subscription.

## ABOUT TRUEVIEW RECKON

TrueView Reckon is an Amazon Web Services (AWS) hosted platform that is used for a variety of purposes in TrueView (and other) workflows. It provides services such as (items marked with a \$T are extra cost, paid in TrueView Points):

- Project data hosting and visualization (\$T)
- Data archival (\$T)
- Management and automatic delivery of sensor calibration files
- Automatic sensor health check
- Transfer of sensor Cycle data to GeoCue for technical support
- Management of TrueView Points for services that are paid via a metering scheme (marked in this list with \$T)
- Transaction history of sensor usage
- other related services

TrueView Reckon is accessed from within LP360 Drone in various workflows. These workflows might require an LP360 Drone user to provide their Reckon login credentials. TrueView Reckon also has a web interface for data visualization and account monitoring.

Every customer with a TrueView or guest sensor (whether purchased or a rental) is provided a Reckon account.



## A TRUEVIEW CYCLE

All TrueView sensors, and microdrones sensors running the latest firmware, write their various data streams to a standard file folder structure called a “Cycle” on the UMS (Universal Mass Storage). The original meaning of *cycle* was an on/off cycle of the sensor. It is possible to have multiple collections (flights, in the case of a drone) in a single Cycle, so it is not necessarily correct to think of Cycle as being synonymous with flight, though it is typically.

## System Configuration File (SCF)

If and update is needed the System Configuration file (SCF) (**SystemConfiguration.json**), must be placed on the TrueView Universal Mass Storage (UMS). The file will be copied into the internal storage of the payload and the Cycle\System folder as each Cycle is created. Once the SCF is updated it can be deleted from the UMS. The SCF contains information on the calibration parameters of all components for each TrueView system and is used by LP360 to process TrueView data. The latest calibration file for each sensor is stored on the TrueView Reckon portal.



NOTE

For concerns regarding calibration or to verify the SCF requires updating contact [GeoCue Customer Support](#) for more information.



## FCC AND IC COMPLIANCE



This device complies with Part 15 of the FCC Rules and Industry Canada License-exempt RSS standard(s). Operation is subject to the following two conditions:

1. This device may not cause harmful interference.
2. This device must accept any interference received, including interference that may cause undesired operation.

Changes or modifications not expressly approved by the party responsible for compliance could void the user's authority to operate the equipment.

Parts used in the construction of this device may contain radio components or functionality. The parts were selected based upon availability and are compliant with FCC and Industry Canada rules and standard(s). Compliance statements and / or certification can be obtained within the manufactures' resources.

This device contains the following parts:

Component	Hardware Version ID no.	Product Marketing Name	Firmware Version ID no.	IC no.	FCC no.
Raspberry Pi-4 model B	Raspberry Pi,4 model B	Raspberry Pi,4 model B	n/a	20953-RPI4B	2ABCB-RPI4B
APPLANIX APX-15 /20	n/a	n/a	n/a	Please see Manufacturer Compliance Certificate	Please see Manufacturer Compliance Certificate
Hesai PandarXT-32	n/a	n/a	n/a	Please see Manufacturer Compliance Certificate	2ASO2PANDARX

**Table 1. Radio components in the TrueView 515vB payload.**





## NOTICE TO USERS

### Warnings

Read these warnings carefully before you use TrueView 515vB payload series. Failure to do so can result in serious injury.



WARNING

Do not attempt to take apart, reassemble, or alter the TrueView 515vB payload as it will void the warranty. Only qualified personnel can service the payload.



CAUTION

Do not disconnect the power from the drone/payload until the payload is fully powered **OFF**.



CAUTION

Do not expose the payload to rain or water.



CAUTION

This payload has an operation range of -10°C up to 50°C. Operation outside this temperature range can lead to damage to the payload.



WARNING

This is a Class 1 laser and is not hazardous however, do not look directly at the laser light or direct it toward people at any time. The payload contains infrared lasers which are invisible to the human eye and can cause harmful exposure and injury.



WARNING

Do not block the cooling vents located on the right and left side of the payload. If you block the cooling vents the payload will become too hot.

## Disposal



Do not put batteries or other electrical equipment into general waste containers. Substances in batteries are harmful to human health and the environment. Dispose of electrical equipment at a collection point or recycling center. Contact your local authority for detailed information.

**OVERVIEW****System items**

<b>Item</b>	<b>Quantity</b>
TrueView 515vB payload	1
Travel case	1
32GB UMS flash drive (Only use the UMS flash drives provided by GeoCue) <sup>(1) (2)</sup>	1
AV18 GPS antenna	1
Debug cable	1
TrueView payload internal battery	1
RRC battery charger	1
RRC battery charger cable	1
Battery power cable	1
Safety wire	1
Spares kit lens cleaning cloth and foam filter	1

**Table 2. List of system items.**

<sup>(1)</sup>To purchase additional UMS flash drives please contact [GeoCue Customer Support](#) or your Sales Representative. Quote article number A004105.

<sup>(2)</sup> A 64GB version of the UMS flash drive is now also available please contact [GeoCue Customer Support](#) or your Sales Representative for more information.

**Product Specifications**

<b>Model</b>	TrueView 515vB
<b>Year of release</b>	2022
<b>Mass</b>	1.75kg
<b>Dimensions</b>	30.5 cm x 17.5 cm x 16.7 cm

**Table 3. List of product specifications.**



Technical Specifications

Specification	Value
Data Collection	LiDAR + imagery
Laser Scanner	Hesai Pandar XT-32
LiDAR Beams/Returns	32/2
LiDAR Range – Usable	80 m @ 20% reflectivity
Pulse Repetition Rate	640 kHz
Cross-track Field of View(FOV)/Combined	120°
Position and Orientation System (POS)	Applanix APX-15/20
Accuracy	Better than 5cm, RMSE
Precision	Better than 5cm at 1 $\sigma$
Camera Sensor	Dual 1" mechanical shutter, hardware mid-exposure pulse, 20 MP, RGB

**Table 4. List of technical specifications.**



## TRUEVIEW HARDWARE INTEGRATION KIT (M600)

The True View 3DIS was designed to be used with the GeoCue True View Integration kit, which includes an antenna mounting plate and a DJI Ronin gimbal mount with vibration dampeners. If your True View 3DIS and M600 were purchased through GeoCue, the antenna mounting plate and Ronin mount were installed by a GeoCue technician. If you purchased your M600 from a third party, you will need to install these components before using your True View system. The following steps explain how to install your True View integration kit.

### Installing the Top Plate

1. To install the top plate, you will need the following components:
  - a. Top plate with antenna mast. ( [Figure 1](#) )



**Figure 1. Top plate with antenna mast.**

- b. Set Screw (4). ( [Figure 2](#) )

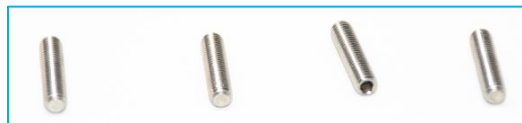

**Figure 2. Set screws.**

- c. 50mm Spacer (4). ( [Figure 3](#) )



**Figure 3. Spacers.**



- d. Hex Driver – 1.5mm and 2mm. (Figure 4)



Figure 4. Hex driver.

- 2. On the drone, remove the 4 screws indicated below (Figure 5). These screws will be used to attach the mounting plate later, so save them for step 5.



Figure 5. Prepare for mounting.

- 3. Apply Loctite to the 4 Set Screws and install in the empty screw spaces from Step 2 using a 1.5mm hex driver (Figure 6).



WARNING

Do not overtighten. If screws are too tight, they will press into the plastic plate below and could cause the plate to crack.

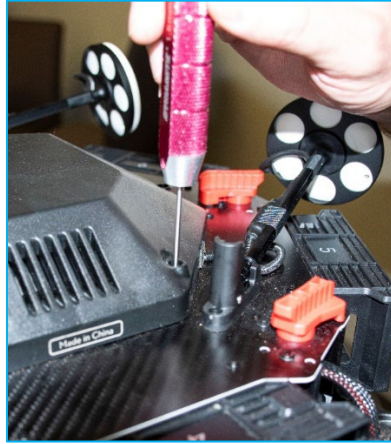

Figure 6. Install set screws.

4. Install the four 50mm spacers on top of the set screws (Figure 7).

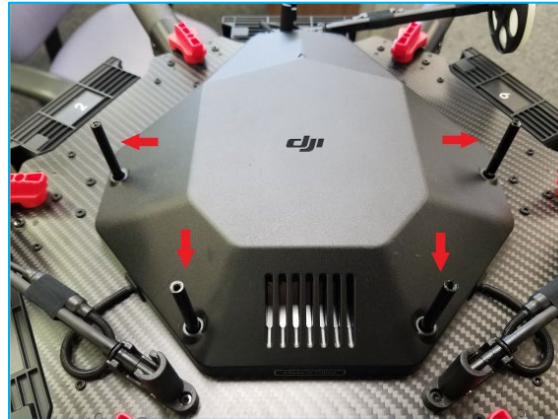

Figure 7. Install spacers.

5. Line the plate up on top of the spacers. Apply Loctite to the 4 screws removed in Step 2 (Figure 8) and secure the plate to the top of the spacers.

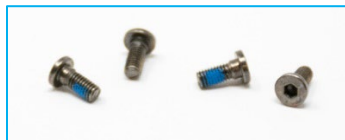
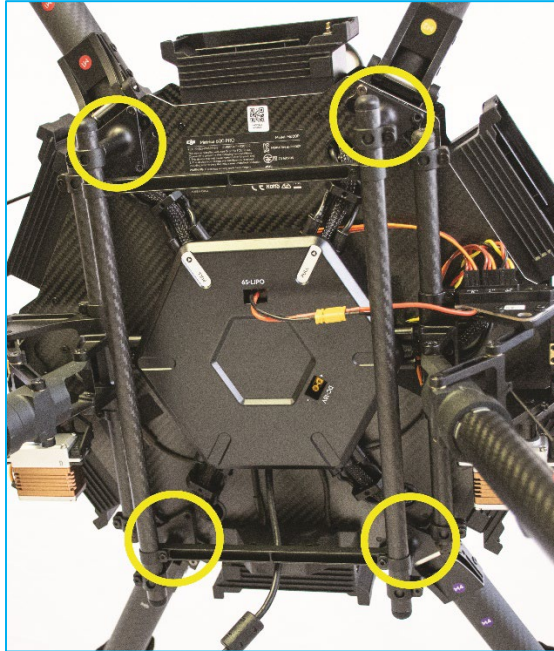

Figure 8. Loctite the removed screws.



## Installing the Ronin Mount

1. On the drone, remove the 3 screws on each leg of the stock mount (**Figure 9**). Keep the screws, they will be used again.



**Figure 9. Remove stock mount screws.**

2. On the Ronin Mount, loosen the screws that hold the legs to the rails enough so that they can be rotated (**Figure 10**).

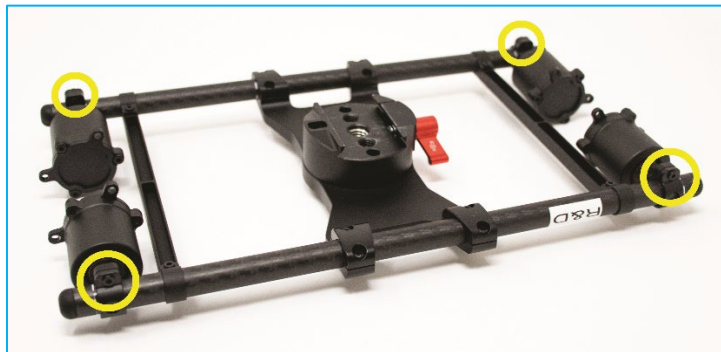

**Figure 10. Loosen leg screws.**

3. Rotate legs so that the mount stands off the drone (**Figure 10**).





Figure 11. Rotate Legs.

4. Using the screws removed from the drone in *Step 1*, apply Loctite to each screw and install the mount with the red lever facing the back of the aircraft (**Figure 12**).

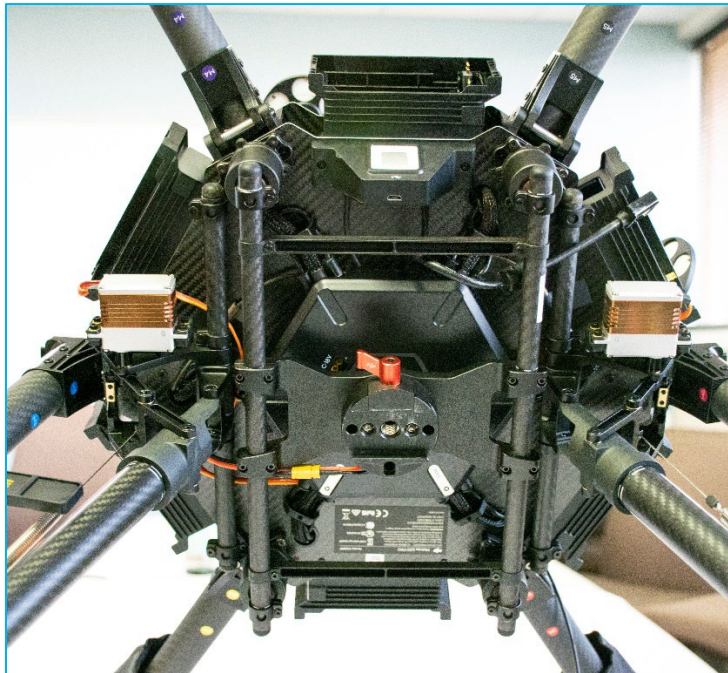

Figure 12. Install mount.



## TRUEVIEW HARDWARE INTEGRATION KIT (M300)

The TrueView 3DIS was designed to be used with the GeoCue TrueView Integration kit, which includes an antenna mast base and a TrueView mounting bracket for M300 with vibration dampeners. If your TrueView 3DIS and M300 were purchased through GeoCue, the antenna mast base and TrueView mounting bracket were installed by a GeoCue technician. If you purchased your M300 from a third party, you will need to install these components before using your TrueView system. The following steps explain how to install your TrueView integration kit.

### Installing the Antenna Mast Base

1. To install the antenna mast base, you will need the components listed below.
  - a. (1) Antenna Mast Base (**Figure 13**)

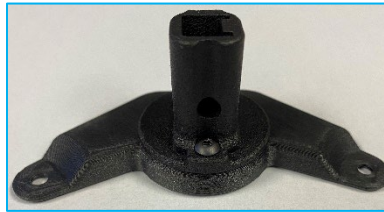

**Figure 13. Antenna mast base.**

- b. Torque screwdriver set to 5.7 Inch-Pounds (INLB) (**Figure 14**)



**Figure 14.**



- c. Threadlocker – Removeable Blue 242.
  - d. (2) M3 x 0.5 - 8mm length screw
  - e. (2) 4mm Spacer
2. Apply Threadlocker to all screws and tighten to 5.7-inch pounds. Figure 15 shows the installation diagram.



NOTE

The bottom side of the antenna mast base has two-sided tape that needs to be unpeeled before placing on the aircraft.

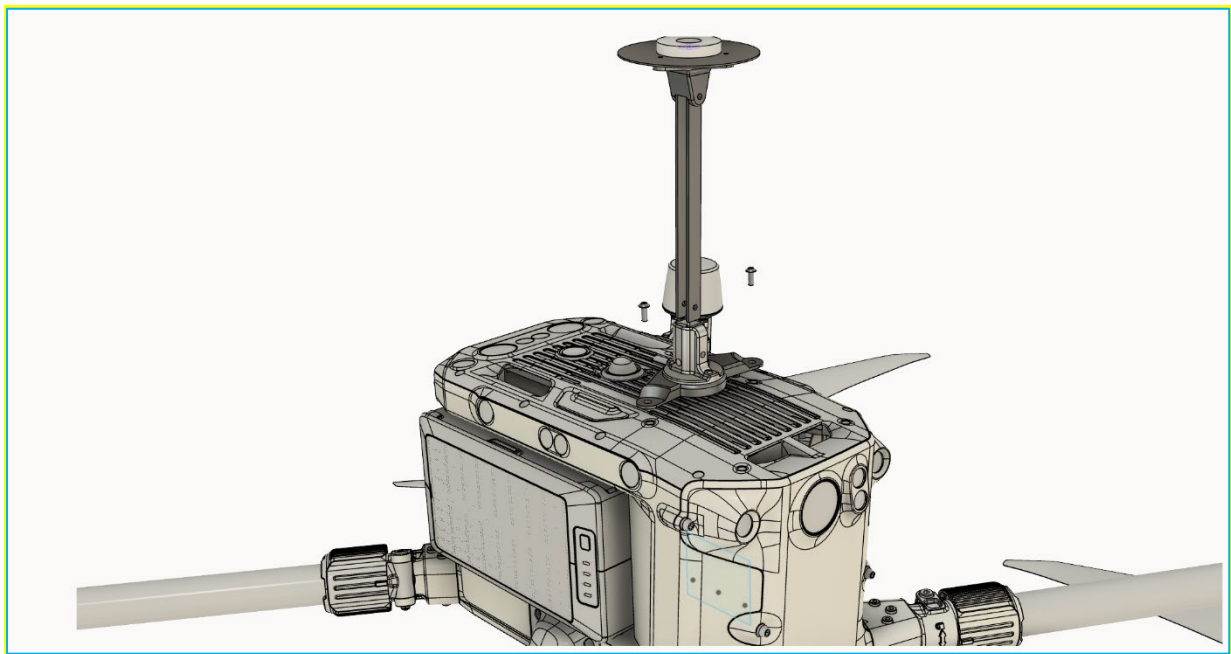
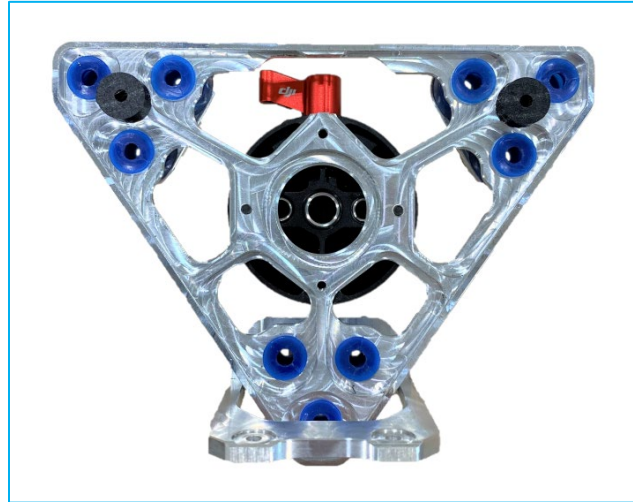

Figure 15.



## Installing M300 TrueView Mounting Bracket

- g. M300 TrueView mounting bracket (**Figure 16**) with slanted TPU spacer (**Figure 18**) attached.

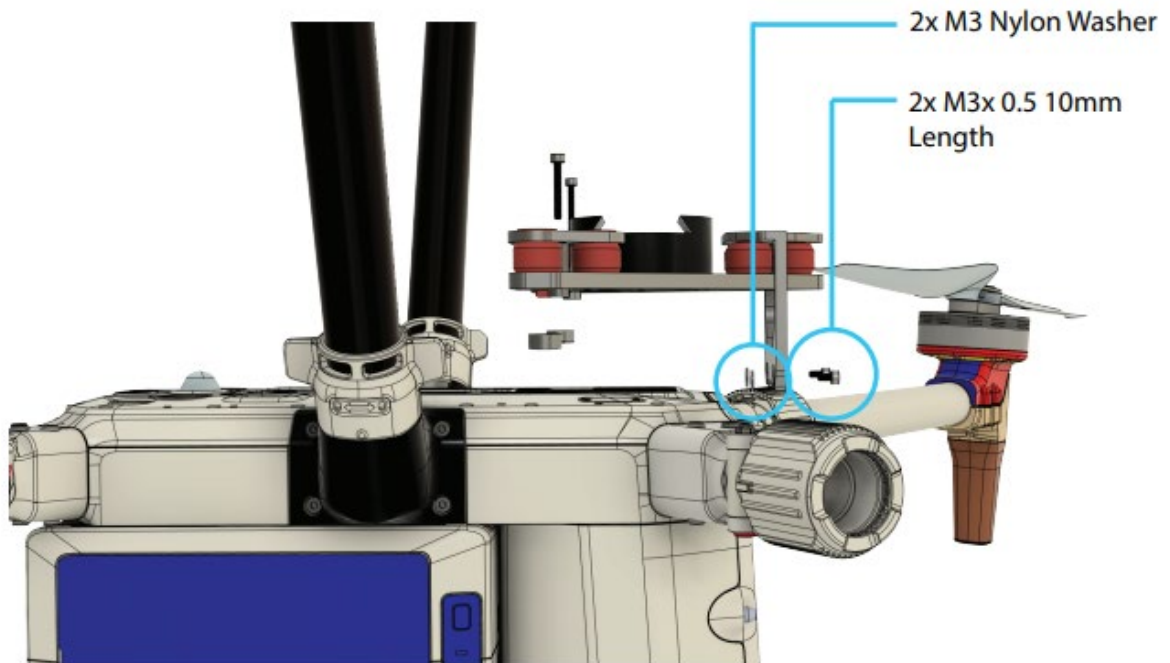

**Figure 16. M300 TrueView bracket.**

- h. (2) M3 x 0.5 - 10mm length screw
- i. (2) M3 Nylon Washer
- j. (2) M3 x 0.5 – 20mm length screw
- k. (2) Slanted TPU Spacer



1. Invert the drone so the bottom is facing up.
2. Apply threadlocker to the M3 x 0.5 – 10mm length screws and install on the front two hole of the bracket and aircraft body. The M3 nylon washers go between the M300 body and the TrueView bracket (**Figure 17**). Tighten screws with torque wrench using 5.7 inch-pounds of torque.



**Figure 17.**

3. Place TPU spacers between the bottom of the aircraft and the TrueView bracket. The angle of the spacers will match the aircraft body (**Figure 18**).



4. Apply thread locker to the M3 x 0.5 – 20mm screws and install the screw into the TrueView mounting bracket and aircraft body (Figure 18). Tighten screws with torque wrench to 5.7 inch-pounds.

**\*\* Note that the angle of the spacers match the drone body. \*\***

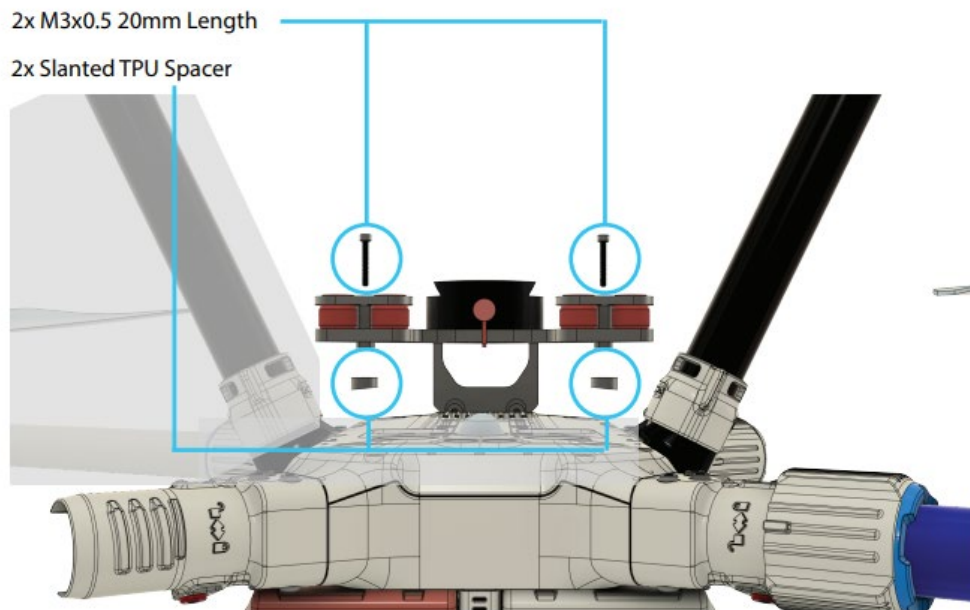

Figure 18.



## TRUEVIEW 3DIS INSTALLATION

The TrueView 3DIS mounts using a standard DJI Ronin mount on the DJI M600. The instructions below describe how to install the TrueView 410 on the M600 when you are ready to use the system to collect data.

1. Place the drone on a stable surface with the landing gear down.
2. Turn the red lever (**Figure 19**) on the Ronin mount until it is loose, but do not remove it completely.

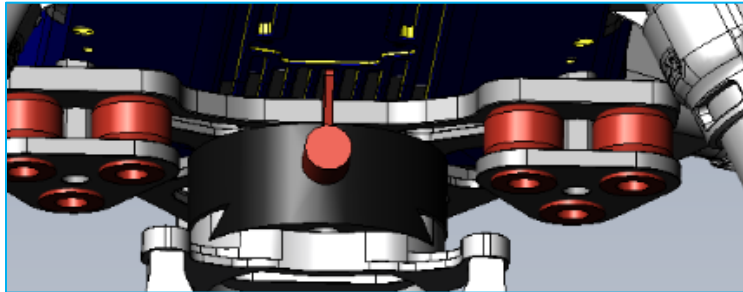

**Figure 19. Ronin mount locking lever.**

3. Align TrueView so that the battery compartment is facing forward on the drone and the laser scanner is towards the back.
4. From the back of the drone, lift the TrueView up to the mount from the left side and slide the TrueView mount into the Ronin mount (**Figure 20**). Slide until the TrueView dove tail is in the center of the Ronin mount (**Figure 21**).

Insert payload from side of Ronin mount.

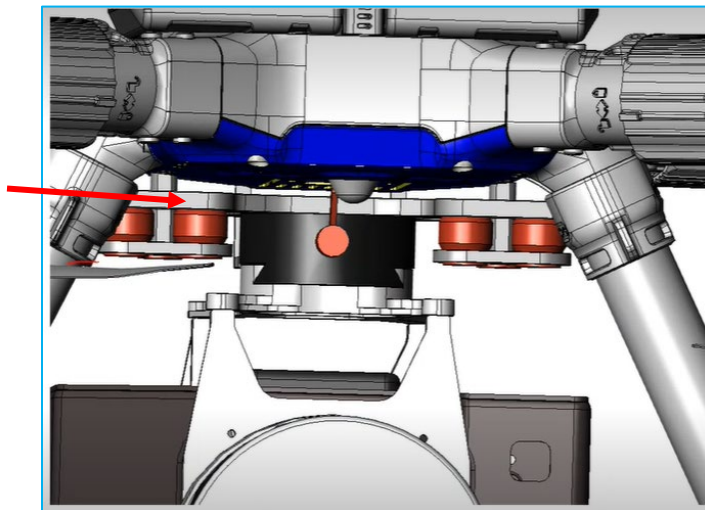

**Figure 20. Ronin mount.**

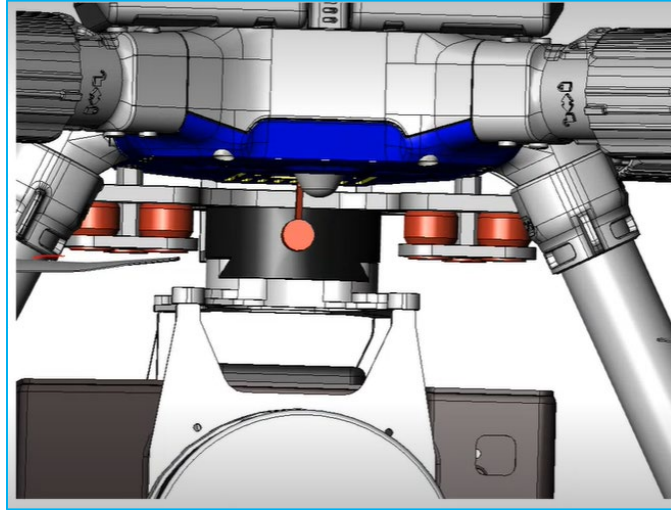

Figure 21. TrueView payload in Ronin mount.

5. Tighten the red lever until the TrueView is tightly locked in place.
6. Loop the safety lanyard through the upper metal plate of the TrueView and around one of the bars of the payload mount and close the safety lanyard (Figure 22).

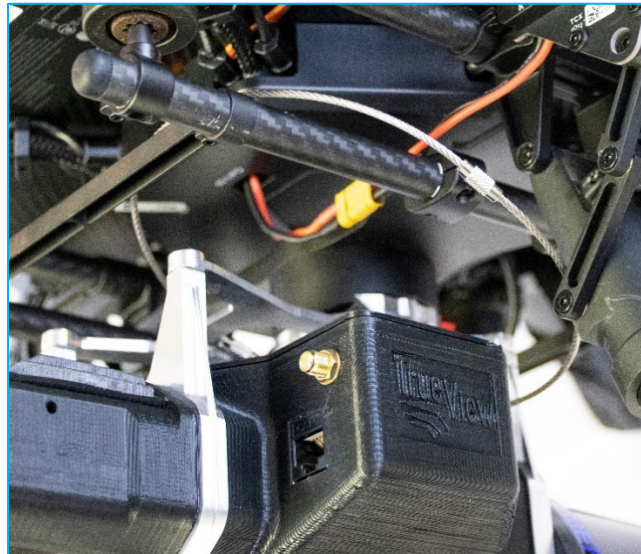

Figure 22. Safety lanyard.





Figure 23. GNSS connector.

1. Attach the GNSS antenna cable to the TrueView unit GNSS connector (Figure 23), screw the antenna onto the antenna mount (Figure 24., Figure 25, Figure 26) and insert the antenna mount into the mast holder. Be sure to secure any excess cable but leave enough slack to prevent tension on the connector.



Figure 24. GNSS antenna installed on DJI M600.



Figure 25. AV14 GNSS antenna installed on M300.

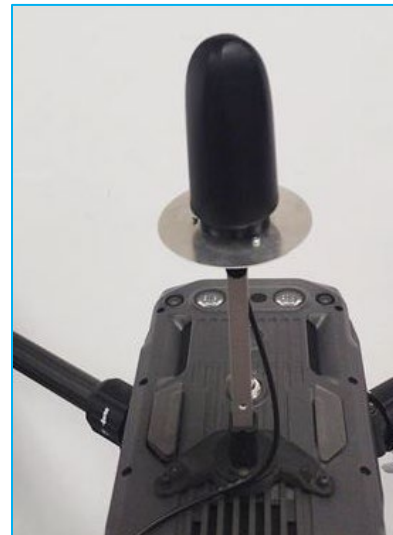

Figure 26. AV18 GNSS antenna install on M300.

2. Attach the GNSS antenna cable to the TrueView unit (Figure 25) and screw the antenna onto the antenna mount (Figure 24.) or insert into the revision 2 antenna mount. Be sure to secure any excess cable but leave enough slack to prevent tension on the connector.



## TRUEVIEW BATTERY

The TrueView 3DIS can be powered by its own 3200 mAh removable lithium-ion battery. The TrueView power system was designed to be standalone and does not use power from the aircraft’s power system. This ensures that TrueView does not interfere with critical flight functions. You can expect to get about 90 minutes from each battery under normal conditions, but cold temperatures can significantly reduce battery life.



Figure 27. Removeable battery.

The TrueView 3DIS comes with two RRC2054 batteries (Figure 27), which have built-in charge status indicators, and a charging station.



## TRUEVIEW EXTERNAL POWER ADAPTER

The TrueView 3DIS can also be powered by a drone specific external power adapter that replaces the battery.

For the DJI M300 drone an OSDK port compatible power adapter is provided. Common connections like XT60 or XT90 power connectors can be provided upon request as custom setups for other models of drones.



NOTE

External power module installation will vary depending on drone model. Please contact [GeoCue Technical Support Team](#) for instructions if not provided with the initial purchase.



Figure 28. External power adapter.



## TRUEVIEW DATA STORAGE DEVICES

### UMS

The TrueView UMS (Universal Mass Storage) device is the media attached to the TrueView sensor on which will be written during flight operations and system wind-down.

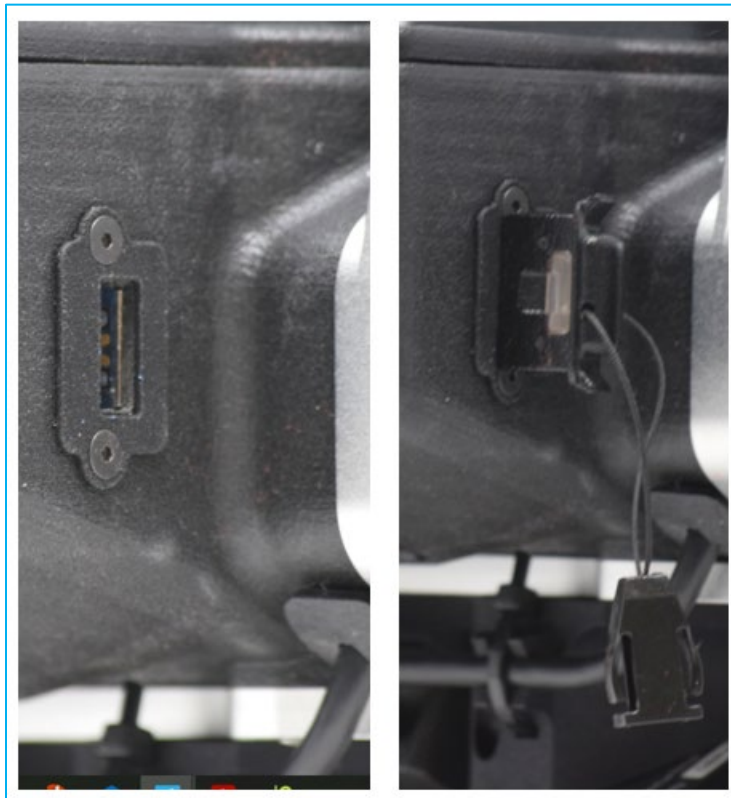

Figure 29. USB port (left) UMS inserted into USB port (right).



## FIRMWARE UPDATE

The TrueView 515vB users will install the firmware update.

Please make sure the following conditions are met before updating the payload firmware.

- ✓ The payload is mounted and properly connected to the drone.
- ✓ The drone battery is fully charged.
- ✓ The drone with the payload is outside with visibility to the sky where the GPS fix can be found.
- ✓ The mdCA is running with a DDL connected to verify payload initialization.
- ✓ Make sure the UMS storage device is available.

### **Firmware installation:**

1. Make sure the above prerequisites are met.
2. If not already done, download the latest version of the firmware.
3. Make sure the drone and payload are powered OFF and that the battery is disconnected.
4. Install the TrueView 515vB UMS storage device into the computer.
5. Copy all the files with the **.mdpkg** and **.json** extension on the UMS storage device.
6. Power ON the TrueView 515vB payload as you would do for a normal flight.
7. The firmware will install automatically. Allow up to 2 minutes for the process to complete. The two lights on the front of the payload will blink blue for 10 seconds when installation is successful. The payload will reinitialize automatically upon completion.
8. If no flight is required, follow the instructions in the **Multifunction Button** section to shut off the payload. Once completed power off the drone by disconnecting the drone battery.

### **Verification of the update:**

1. Remove the UMS storage device from the TrueView 515vB payload and insert it into the computer.
2. Navigate to the UMS storage device drive and verify the file extensions was changed to **.installed** on every **.mdpkg** and **.json** file. This means the installation of the firmware was successful. **Remove the install files once installation has been successful.**
3. GeoCue recommends completing a flight after the firmware update to quality check the data before the next operation.

Please contact [GeoCue Customer Support](#) if you have any questions and /or require assistance.



## TRUEVIEW 515VB FIELD OPERATIONS

### Base Station

The TrueView 3DIS records GNSS signals during flight which will be corrected later in LP360. This type of system is known as a PPK system. Base station processing methods should be considered during the planning process because the user will need to determine how they plan to correct their flight data before collecting. TrueView GNSS signals can be corrected by one of three methods:

1. **Single base** – Single base, as the name implies, is a static recording from one single base station which is close in proximity to the flight area. Corrections are computed at the base station, then applied to the data collected by TrueView. CORS stations can also be used for single base processing if they are within 12 miles of the flight area and record static data at 1Hz. The base station must also record both L1 and L2 signals and must be during the same time as the flight. Single base is the only processing method if you plan to process with the local option selected.
2. **SmartBase** – SmartBase is a cloud processing option that uses multiple CORS stations to compute base corrections for your flight. Smart base processing allows for longer baselines from the flight area and the user does not have to setup a base station or download CORS data from a nearby station. This option still requires an existing CORS network in the area of flight. Users can go online to the Applanix SmartBase website and determine if their flight location is covered by the SmartBase network and estimate the quality of the results.
3. **PP-RTX** – PP-RTX is a cloud processing option that does not require a base station or CORS network. PP-RTX corrections can be computed anywhere. Accuracy is reduced using this method but can be used as a last resort option in the event of base station failure or lack of CORS network.

More information can be found in our knowledge base articles:

<https://support.geocue.com/positioning-options-in-true-view-workflows/>

<https://support.geocue.com/single-base-vs-smartbase-vs-pp-rtx>



## Pre-Flight

1. Prepare the drone for flight and insert the battery into the TrueView unit (**Figure 30**), if not using the TrueView External Power Adapter previously installed on the drone.



NOTE

External power module installation will vary depending on drone model. Please contact [GeoCue Customer Support](#) for instructions if not provided with the initial purchase.



**Figure 30. Insert TrueView battery.**



WARNING

It is very important to make sure the battery is sufficient charged before every flight.

2. Lift all antennas up and if using the foldable GNSS TrueView antenna, tighten the nut (**Figure 31**). If using the square tubing mast, insert the mast into the mast port and press until firmly seated (**Figure 32, Figure 33**).

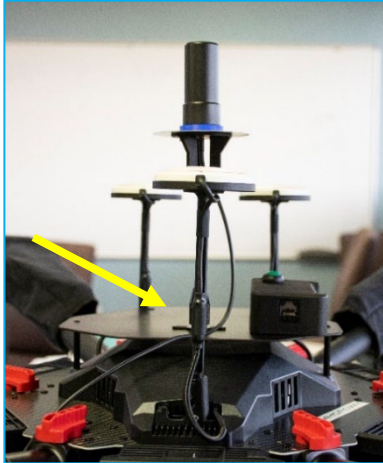

Figure 31. TrueView GNSS antenna on DJI M600.



Figure 32. AV14 GNSS antenna installed on M300.



Figure 33. AV18 GNSS antenna installed on M300.

3. Place the drone in an open area where you intend to takeoff. TrueView will need an unobstructed view of the sky. Avoid placing the drone near large metal objects such as buildings or vehicles to avoid signal disturbance.
4. Insert the UMS drive.



WARNING

It is very important to make sure that all cables are secured to prevent contact with the propellers during the flight.





5. Turn on the TrueView unit with the switch located in the battery compartment (Figure 34).



Figure 34. TrueView power switch.

6. Close the battery compartment door and lock the latch.
7. The TrueView will now cycle through the power up procedures.

## Disable Obstacle Avoidance

### IMPORTANT M300 Only

The integration of the TrueView 3DIS system will cause disruption to the M300's built-in obstacle avoidance detection systems. If these systems are not disabled, they can cause erratic and potentially dangerous behavior including loss of control of the drone. To disable obstacle avoidance, perform the following steps:

1. Launch the DJI Pilot application, open a mission, or go into manual view.
2. Tap the Ellipsis menu (...) on the top right corner of the screen.
3. Tap the second icon from the top Obstacle Sensing Settings
4. Tap each tab for Horizontal, Upward, and Downward tap the toggle button off for each category. (Figure 35)

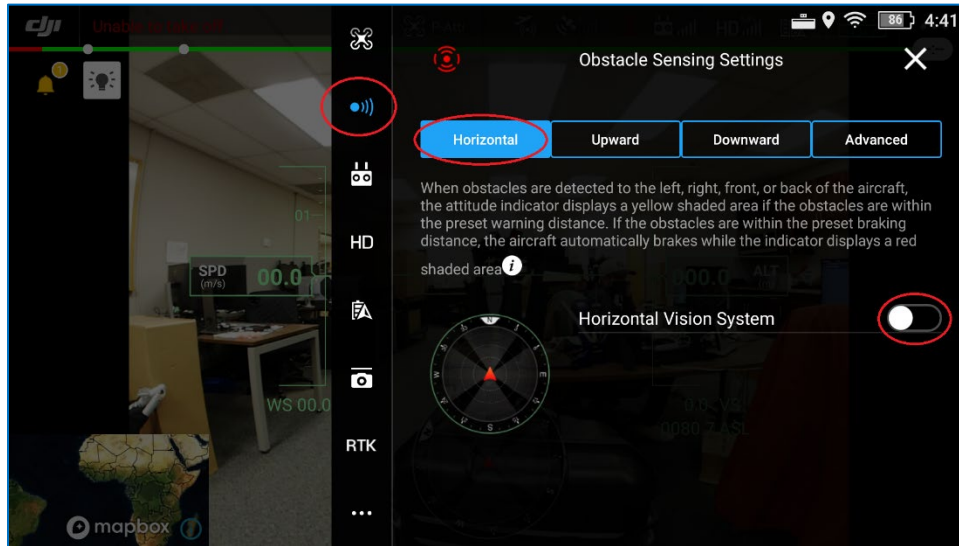

Figure 35. DJI Pilot - Obstacle sensing settings menu.

## Center of Gravity (GC) Calibration

### IMPORTANT M300 Only

When heavy payloads are carried on the M300 platform a center of gravity (GC) calibration must be performed there is any change to the payload. This would include if you switched from a TrueView 410 to a TrueView 515 or DJI P1 or even switch to flying without a payload. The aircraft must be in flight and hovering to start the calibration. It is ideal to perform this calibration in a wind free environment. To perform the GC calibration, perform the following steps:

1. Launch the DJI Pilot application, open a mission, or go into the manual view.
2. Tap the Ellipsis menu (...) on the top right corner of the screen.
3. Stay within the Flight Controller Settings tab and scroll to the bottom of this screen.
4. Tap the Center of Gravity Auto Calibration Button and follow the instructions. (Figure 36)

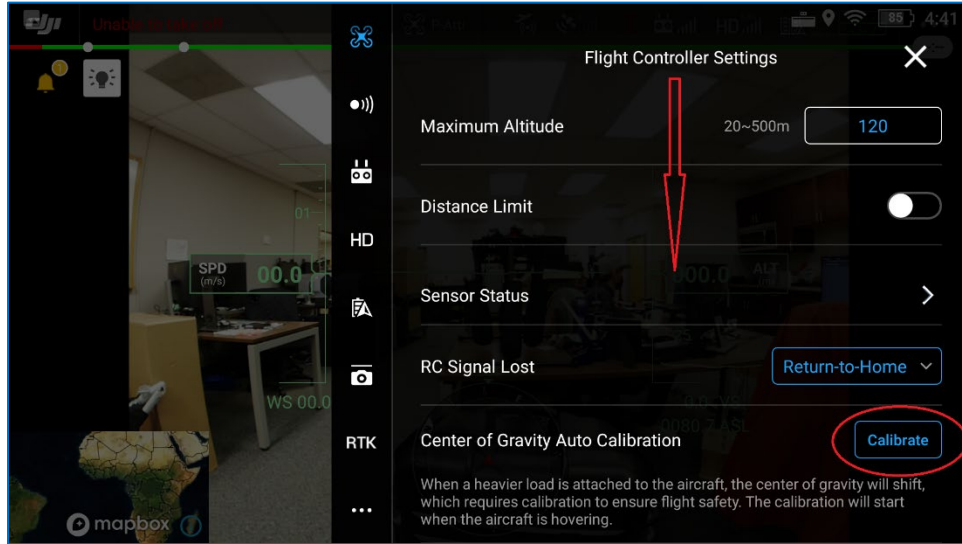

Figure 36 DJI Pilot - Flight controller settings menu.



## LED Lights

1. When the power switch is turned on, the system will go through the startup procedure and all LED lights ([Error! Reference source not found.](#)) will flash yellow. After a few seconds, each LED light will begin to show a sequence of colors indicating status.

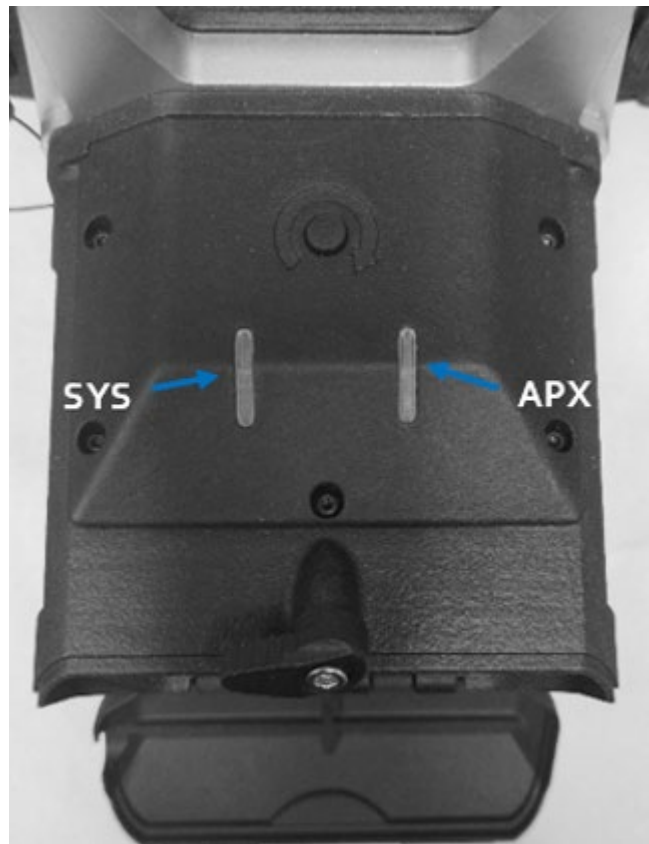

Figure 37. LED lights.



**Table 5** shows all the lighting sequences, LED messages, and their meanings. **Table 6** shows how to interpret the symbols in the table.

SYS	APX	LED Readout	Meaning
		No light	No power, or complete to download recording file from APX and turn off APX
		Slow blink	Turn on payload
		Fast blink	Initializing
		On - solid	Start APX (power on)
		Slow blink	APX is operating normally
		Fast blink	Enabling APX data recording
		Slow blink	APX setup is ready
		On – solid	Complete initialization and ready to fly
		Slow blink	In flight-collecting data
		Fast blink 1x	SII (drone error)
		Fast blink 2x	Camera error/off/not presents
		Fast blink 3x	APX error
		Fast blink 4x	APX Application file error (not present or corrupted)
		Fast blink 5x	Storage error
		Fast blink	Stop collecting and start downloading data to UMS
		On – solid	Complete data download to UMS and prepare to turn system off
		Simultaneous fast blink	Firmware installation

**Table 5. Status LED chart.**





Step	Action
	Black circle with a white outline indicates the LED status light is OFF.
	Starburst of any color indicates the LED status light is blinking. Speed will be indicated by "fast blink" or "slow blink".
	Circle of any color other than black indicates the LED status light is solid.

Table 6. Status LED legend.

### Takeoff Preparation

1. Turn the drone and transmitter on and connect to the drone on the iPad.
2. Arm the drone, perform takeoff, and climb to the mission altitude.
3. Once the system travels 25 meters from takeoff (X, Y, and Z), it will begin recording data.

### Multifunction Button

The multifunction button can be used to start/stop data collection or to abort an operation following the combinations below:

Button Press Type	Payload Reaction	LED Readout
Short press	Start data collection if payload is initialized (SYS LED is solid green).	SYS LED will switch to a slow blink green to indicate data collection started.
Long press (5 seconds)	Terminate and delete current data including log files. Note: This can be triggered at any state of the payload initialization.	SYS LED will fast blink yellow followed by solid white. Note: Once SYS is solid white payload can be turned OFF.
Short press (after collecting data started)	Switch to stop collecting phase and start downloading data to UMS.	SYS LED will switch to slow blink white followed by solid white or red error state. Note: Payload can be turned OFF once either solid white or error state SYS LED is on.

Table 7. Multifunction button instruction chart.

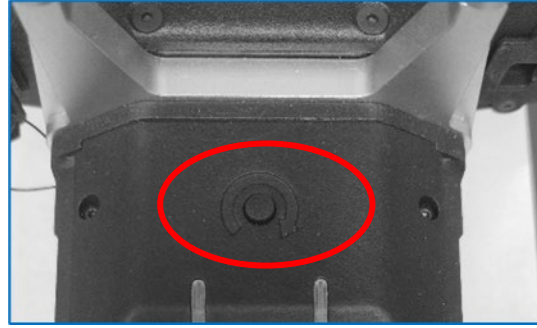

Figure 38. Multifunction button.

### Heading Alignment Maneuver

**The heading alignment maneuver needs to be done after takeoff, before flying the mission, and after the mission prior to landing for each flight. This maneuver is critical for getting accurate heading corrections for the IMU and will impact the results of the data if not performed.**

1. Before takeoff, identify a safe direction to perform the heading alignment maneuver. Avoid areas with people, bodies of water, and obstacles.
2. After takeoff, once at mission altitude, let the drone hover in place for two seconds.
3. Push the right stick all the way forward quickly and hold until the drone accelerates to 10m/s. This should take about four seconds. Do not provide any other input. The drone should be accelerating in a straight line.
4. After reaching 10m/s, about four seconds of forward flight, release the stick and leave it centered. The drone will quickly stop.



NOTE

Speeds beyond 12-14 m/s may yield poorer results.

- 5.
6. Wait two seconds, then use the left stick to turn (yaw) the aircraft about 15-20 degrees, then wait a second. (This is for safety; it is intended to prevent the drone from returning directly overhead when you do step 5. Yaw the drone in a direction so that its return path will be clear of people below, and when it returns, it will be at least 15-20m away, and in front of you.)
7. Pull the right stick all the way back quickly and hold until the drone accelerates to 10m/s. This should take about four seconds. Do not provide any other input. The drone should be accelerating in a straight line backwards.
8. After reaching 10m/s, about four seconds of backward flight release the stick and leave it centered. The drone will quickly stop. Wait at least two seconds after it stops before starting the mission.



NOTE

Speeds beyond 12-14 m/s may yield poorer results.

9. Fly the mission you have planned.
10. At the end of the mission allow the drone to return to home, but do not let it descend, a final heading alignment maneuver needs to be done.
11. To take back manual control over the drone.
12. Repeat steps 1-6 again. Make sure that when repeating step 4) that you turn the drone sufficiently that it will be several meters (>5) away from the takeoff location at the end of its backwards travel. This is needed so that when returning automatically, the drone will properly navigate to above the takeoff location before beginning its automatic descent. If you are closer than 5m, it will likely begin descending without aligning with the original takeoff location.
13. After the drone has been stationary for two seconds, hold the (Home) button to begin the automatic return and landing. Watch the drone carefully to be certain it is landing in the intended spot. Otherwise, make the necessary adjustments or take manual control to complete a safe landing.



NOTE

On windy days, avoid starting the maneuver into a headwind, as the drone may not be able to achieve high enough accelerations. Try doing the maneuver crosswind if possible.



Figure 39. Heading alignment maneuver.





## After Landing

1. After landing the SYS LED should be flashing yellow, indicating the system is transferring data. Do not power off the system during this time or it will interrupt the data transfer.
  - a. If proximity mode is disabled or the aircraft does not land within 25 meters of the home point, the SYS LED will be solid green after landing. Press and hold the green button on the TrueView LED controller box until the system LED changes from solid green to flashing yellow.
2. The flashing yellow light indicates the TrueView is writing data to the drive. Be sure not to power off the TrueView or remove the drive during this period.
3. When the system LED changes to solid yellow, the flight data has been transferred to the UMS drive.
4. Power off the TrueView with the power switch in the battery compartment.
5. For missions requiring multiple flights, repeat these steps from the “pre-flight” section of this document. The system should be completely powered off between flights (battery swaps) after the data has been successfully written.
6. Check the data for errors before leaving the field.
7. Field checks the data to verify all data has been collected. The Field check instructions can be found in the LP360 Users Guide.



## DEBUG PORT AND CABLE

The debug port is located on the bottom of the payload. The debug port is used for service and advanced configuration of the TrueView515vB payload.



WARNING

Do not modify or alter the debug port in any way unless instructed to do so by [GeoCue Customer Support](#).

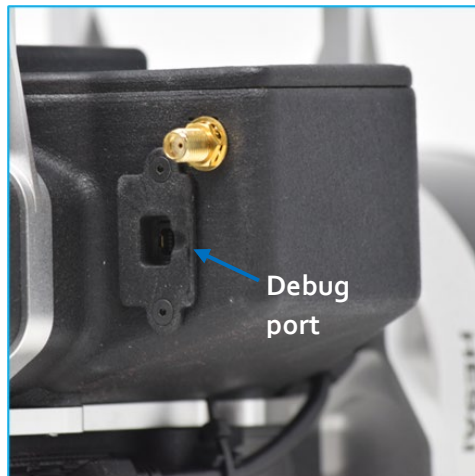

Figure 40. Debug port.

The debug cable is a GeoCue approved accessory to use for service or advanced configuration of the TrueView 515vB through the debug port.



Figure 41. Debug cable.



## Lever Arm Adjustment

The supplied debug cable is a RJ-45 Ethernet to MQ-172 Ethernet adapter cable. If your laptop does not have RJ-45 Ethernet connection, a USB-to-RJ-45 adapter will be required. If you require more information, please contact [GeoCue support](#).

Instructions to connect to sensor using the debug port:

1. Connect debug cable, use USB-RJ-45 adapter if required. Power on sensor.
2. Launch the Windows Network Connection dialog by typing Window Key + R to launch the run command, then type 'ncpa.cpl' without quotes and select OK
3. Right click the icon for your ethernet connection then click properties.
4. Click on Internet Protocol Versions 4 and then click properties.
5. Change the IP Address to 192.168.0.7
6. Change the Subnet mask to 255.255.255.0
7. Change the Default Gateway to 192.168.0.1
8. Change the DNS to 8.8.8.8
9. Click OK to commit the settings.

Once the sensor is connected to the debug port:

1. Open a web browser and type in the IP address for the APX 192.168.0.114
2. If prompted use the credentials admin/password.
3. On the left menu navigate to Receiver Configuration -> INS Configuration -> GNSS Lever Arm
4. Enter the values and click OK then restart the sensor.



## Measuring GNSS Lever Arm Offsets

To accurately position your LIDAR data, the position from the GNSS antenna must be transferred to the onboard positioning system. This is done by using lever arm offsets. If your system is mounted on an M600 or M300 with the GeoCue integration kit, the offsets have been preset by a GeoCue technician and should not need to be modified. If you are not using the GeoCue integration kit, or are installing it on a different aircraft, you will need to measure the offsets, then log in and enter them into the APX-15 (Figure 42), or use a configuration file to update the values in the APX. Contact GeoCue support for the configuration file.

The position is referenced to the APX-15, which is enclosed inside of the housing and cannot be physically measured to. Therefore, you must measure to a physical point on the frame, then add or subtract offsets to the APX-15. The instructions below explain the physical reference points to measure to, and the offsets between those points and the APX-15.

An assumption is made that the sensor will be aligned with the heading of the aircraft, and the aircraft will fly forward during data collection. The battery compartment is the front of the LIDAR sensor, so it should face the heading (front of aircraft).

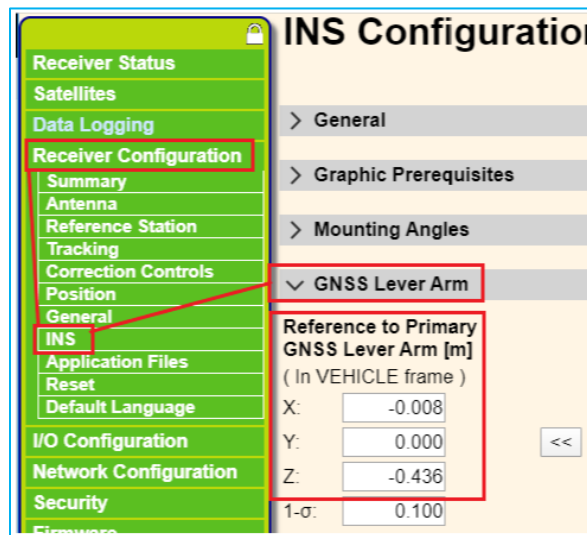

Figure 42. GNSS lever arms.



## Z OFFSET

The Z offset is the distance from the APX-15 to the GNSS antenna phase center in the up/down direction. If the GNSS antenna is above the APX-15, the offset is negative. If the antenna is below the APX-15, the offset is positive. The reference point for Z will be the top of the bottom aluminum mounting plate (Figure 43) where the cameras are attached. The APX-15 is 1.644cm above this plate.

A tip for measuring Z is to install the and GNSS antenna on the aircraft and place it on a table. Measure from the bottom of the antenna (Figure 44) to the table, then add 3.7cm to this measurement. 3.7cm is the offset from antenna phase center to the bottom of the antenna. Then measure up from the table to the aluminum plate. Subtract the distance from the table to the plate, then subtract 1.644cm to get the distance from antenna phase center to the APX-15.

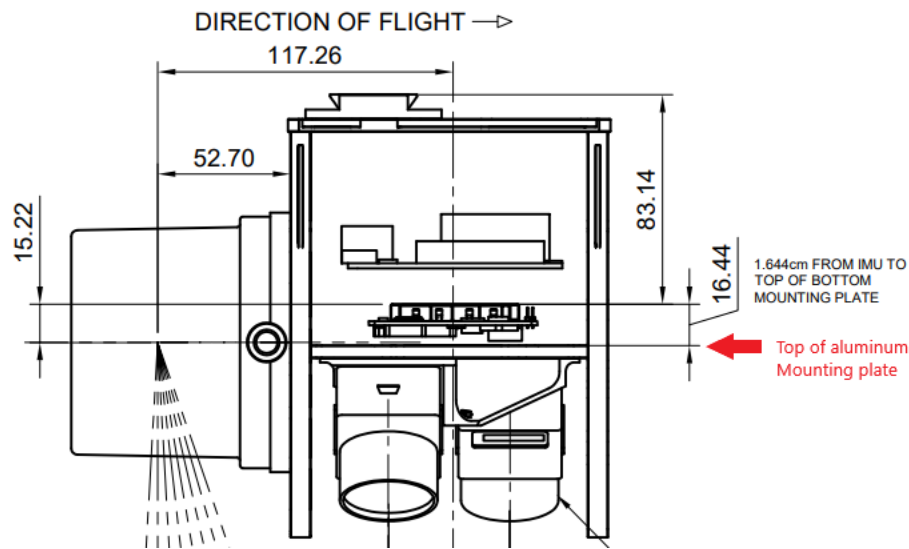

Figure 43. 515vB measurements.



Figure 44. Bottom of GNSS antenna.



### X OFFSET

The X offset is the distance from the APX-15 to the GNSS antenna, in the direction of the heading of the aircraft. If the antenna is forward of the APX-15, the X offset is positive. If the antenna is behind the APX-15, the offset is negative. The reference point is the rear aluminum mounting plate (Figure 45). Measure to the reference point and add or subtract 6.456cm to the offset to get the measurement from your antenna to the APX-15.

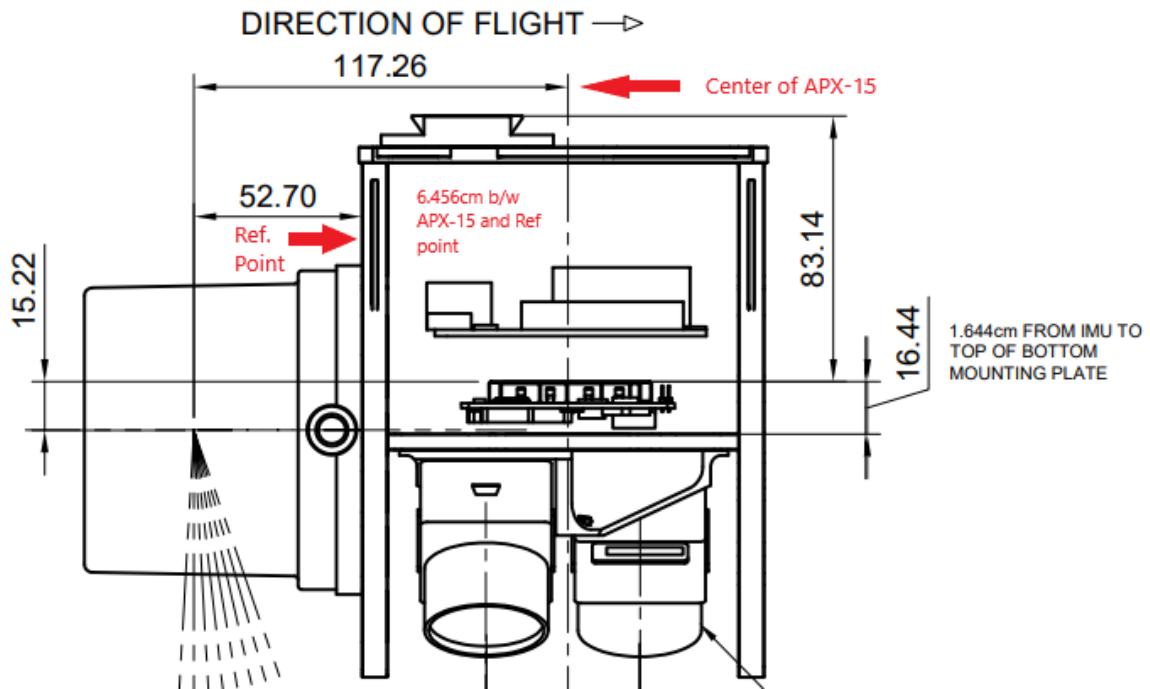

Figure 45. TrueView 515vB measurements.



## Y OFFSET

The Y offset is the distance from the APX-15 to the GNSS antenna, perpendicular to the heading of the aircraft. If you are standing behind the aircraft looking in the direction of the heading, the offset will be negative if the antenna is left of the centerline of the APX-15. The offset will be positive if the antenna is to the right of the centerline of the APX-15. The APX-15 is aligned with the centerline of the 515vB aluminum mounting frame ([Figure 46](#)).

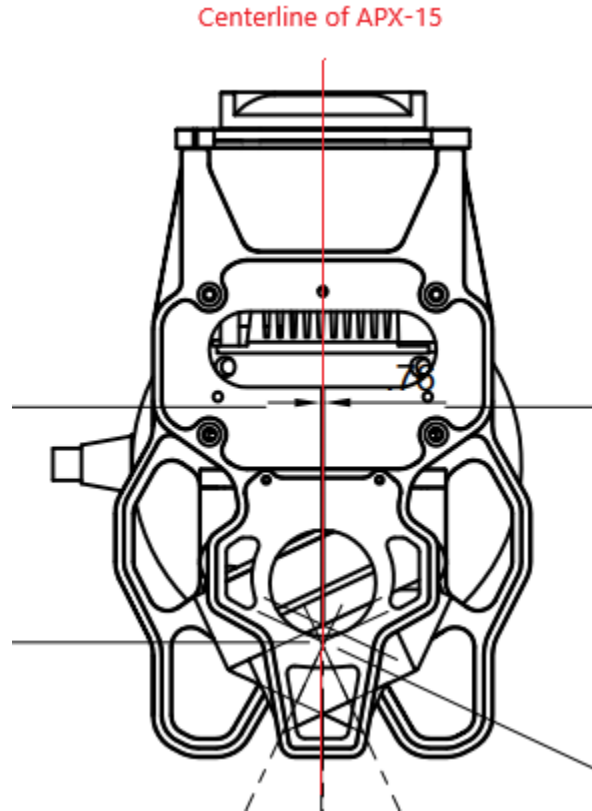

Figure 46. APX-15 centerline.



## TRUEVIEW MISSION CHECKLIST

Step	Action	Notes
1.	Setup base station and turn ON.	
2.	Check mission plan; modify if necessary.	
3.	Complete a safety briefing and flight plan review with field crew.	
4.	Install TrueView on drone mount. LiDAR “top hat” at the back.	
5.	Verify Ronin red lever is fully tightened.	
6.	Verify safety cable attached between TrueView and drone rails.	
7.	Install fully charged TrueView battery pack. Do not turn the unit ON.	
8.	Check all drone GPS antennas upright and secured.	
9.	Verify the TrueView UMS memory stick is inserted.	
10.	Move drone/ TrueView to takeoff location.	
11.	Unfold and secure drone arms, lock in place.	
12.	Unfold drone propellers, visually inspecting for any problems.	
13.	Install fully charged drone batteries. Do not turn the unit ON.	
14.	Double-check all cabling is secure and will not interfere with the props.	
15.	Remove TrueView lens caps; clean lenses/sensor if necessary.	
16.	Power on TrueView using main power button located just above the battery pack (door must be open to toggle).	
17.	Monitor the TrueView status lights waiting for: PWR - Solid Green/Yellow/Red 1. SYS – Solid Green – TrueView has initialized, ready for takeoff date/time stamp received. 2. GNSS – Flashing Blue – Valid date/time stamp received.	
18.	Turn on drone controller then power on the drone as per normal operations.	
19.	Wait for drone to initialize and verify there are no errors showing.	
20.	Safety Check: Area clear of individuals and flight space is clear to fly.	
21.	Manually takeoff and ascend to mission altitude. Verify good LOS to drone and planned flight area.	
22.	Manually preform IMU in-air heading alignment maneuver.	
23.	Initiate mission via flight planning tool.	
24.	Monitor drone/ TrueView during flight as per normal operations.	
25.	Upon completion of last flight line in the mission plan, allow the drone to start the Return to Home sequence, but do not let it descend at the Home point. Toggle drone to manual control (P->A->P) instead.	
26.	Manually perform IMU in-air heading alignment maneuver again.	
27.	Ensure landing area is still clear; complete the landing via Return to Home or manually as preferred.	
28.	After landing, turn off drone.	
29.	Verify SYS light is flashing white (transferring data).	
30.	Monitor the TrueView SYS LED; flashing white means data is being copied to UMS; solid white data copy is complete. Wait for solid white to go to next step.	
31.	Power TrueView OFF using main power switch in battery compartment (door must be open to toggle). Never power OFF while SYS LED is still blinking white indicating a copy operation is in progress; data loss will occur. If SYS LED turns to blinking solid red, it is safe to turn off and move to troubleshoot section or contact <a href="#">GeoCue</a> for further instructions.	
32.	Remove UMS memory stick and pass to post-processing.	





## HARDWARE MAINTENANCE

### Dust Filter

Your 3DIS has a built-in fan to help to cool the internal processors. A filter is needed to prevent dust from entering the system and this filter will need to be changed periodically. A spare filter is included with your sensor spare parts. The steps below explain how to change this filter.

1. First locate the dust cover on your sensor. 400 and 500 series, the dust cover is located on top of the sensor, beneath the aluminum mounting frame (Figure 47). For 600 Series, the dust cover is located on the front of the sensor above the battery compartment (Figure 48).

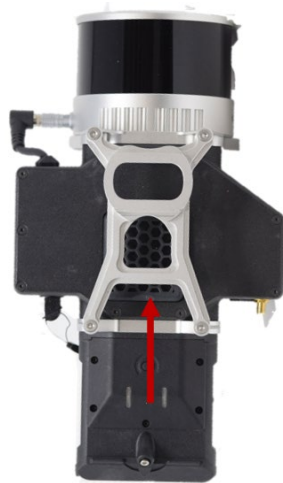

Figure 47. 400/500 series.

2. Remove the dust cover by placing the thumb on the thumb indentation (Figure 48) of the dust cover, apply upward pressure, then lift out to remove.



Figure 48.

3. Remove the old filter from the dust cover.
4. Replace the old filter with a new filter (Figure 49).



- a. It is advised to replace this filter with a new filter, but it can be washed and used again if you are in immediate need. Be sure it is completely dry before re-installing. Do not use a wet filter or moisture could be pulled in by the fan and cause damage to the processors.



Figure 49.

- 5. Re-Install the dust cover.

## FAQ

- **Question** – What is the max distance I can setup my base station from the Flight area?

**Answer** – It is recommended that the base station be within 20 kilometers (12 miles) of the flight area. It is very important for the base to be in an open flat area if possible. Placing the base station close to buildings, trees, or vertical relief can cause issues with PPK processing and accuracy. The base station should be configured to record at 1Hz.

- **Question** - What are the base station requirements for the True ViewTrueView 3DIS?

**Answer** - The minimum requirement base station must include:

- Static observations recorded to some media
- Dual frequency L1/L2
- Ability to transform the observation file to the RINEX format

- **Question** - Which GNSS Constellations are used by the True ViewTrueView 3DIS?

**Answer** - The Position and Orientation System (POS) and supplied GNSS antenna simultaneously supports:

- (NAVSTAR) Global Positioning System (GPS - USA)
- GLONASS (Russia)
- BeiDou (China)
- Galileo (European Union)



## SUPPORT

Our searchable support knowledge base contains information on workflows, tips, hints, and probable resolutions to error messages or commonly encountered situations.

<https://support.geocue.com/>

Normal support business hours are **Monday - Friday, 8 AM — 5 PM** USA Central Time.

Our GeoCue Support website contains general workflow information, in addition to specific issue and error messages that you may encounter. Click on the link and search for information contained in the knowledge base.

If a support request is sent during business hours a representative will typically get back to you within 4 hours. If received after hours, a response will be sent the following day. To speed response time please include the following information in your request:

- Contact information - please include e-mail address and phone number
- Company name
- Product name and version number
- TrueView Model and Serial Number

If your request includes problems pertaining to a specific error message, please include a screen shot of the error message.

For hardware and software support contact: [support@geocue.com](mailto:support@geocue.com)



**LIST OF TABLES**

Table 1. Radio components in the TrueView 515vB payload..... 7

Table 2. List of system items..... 10

Table 3. List of product specifications. .... 10

Table 4. List of technical specifications. .... 11

Table 5. Status LED chart..... 36

Table 6. Status LED legend..... 37

Table 7. Multifunction button instruction chart..... 37

**LIST OF FIGURES**

Figure 1. Top plate with antenna mast. .... 12

Figure 2. Set screws. .... 12

Figure 3. Spacers..... 12

Figure 4. Hex driver..... 13

Figure 5. Prepare for mounting. .... 13

Figure 6. Install set screws..... 14

Figure 7. Install spacers. .... 14

Figure 8. Loctite the removed screws..... 14

Figure 9. Remove stock mount screws. .... 15

Figure 10. Loosen leg screws..... 15

Figure 11. Rotate Legs..... 16

Figure 12. Install mount..... 16

Figure 13. Antenna mast base. .... 17

Figure 14..... 17

Figure 15..... 18

Figure 16. M300 TrueView bracket..... 19

Figure 17..... 20

Figure 18..... 21

Figure 19. Ronin mount locking lever. .... 22

Figure 20. Ronin mount..... 22

Figure 21. TrueView payload in Ronin mount..... 23



Figure 22. Safety lanyard. .... 23

Figure 23. GNSS connector. .... 24

Figure 24. GNSS antenna installed on DJI M600. .... 24

Figure 25. AV14 GNSS antenna installed on M300. .... 24

Figure 26. AV18 GNSS antenna install on M300. .... 24

Figure 27. Removeable battery. .... 25

Figure 28. External power adapter. .... 26

Figure 29. USB port (left) UMS inserted into USB port (right). .... 27

Figure 30. Insert TrueView battery. .... 30

Figure 31. TrueView GNSS antenna on DJI M600. .... 31

Figure 32. AV14 GNSS antenna installed on M300. .... 31

Figure 33. AV18 GNSS antenna installed on M300..... 31

Figure 34. TrueView power switch. .... 32

Figure 35. DJI Pilot - Obstacle sensing settings menu..... 33

Figure 36 DJI Pilot - Flight controller settings menu. .... 34

Figure 37. LED lights. .... 35

Figure 38. Multifunction button. .... 38

Figure 39. Heading alignment maneuver. .... 39

Figure 40. Debug port. .... 41

Figure 41. Debug cable..... 41

Figure 42. GNSS lever arms..... 43

Figure 43. 515vB measurements..... 44

Figure 44. Bottom of GNSS antenna..... 44

Figure 45. TrueView 515vB measurements..... 45

Figure 46. APX-15 centerline..... 46

Figure 47. 400/500 series..... 48

Figure 48..... 48

Figure 49..... 49