



TrueView 540

User Manual



Aerial Surveying | September 2024

Make your work more efficient.





Table of Contents

Table of Contents	2
1 Reading Tips.....	4
1.1 Symbol Description	4
1.2 Disclaimer	4
2 Usage Requirements.....	5
2.1 Environment	5
2.2 Tips Before Using	5
2.3 Tips During Usage	5
2.4 Tips After Using.....	6
3 Product Description.....	7
3.1 Hardware Check List	7
3.2 Delivery of Equipment and Materials	8
3.3 Physical Characteristics	11
3.3.1 Weight and Size	11
3.3.2 Interface Definition	11
3.4 Power Supply and Physical Characteristics	12
3.5 TV540 Technical Data.....	13
3.5.1 Laser Product Classification	13
3.5.2 Max. Measuring Range	13
3.5.3 Max. Operating Flight Altitude AGL	14
3.5.4 Max. Operating Flight Altitude AGL & Point Density	15
4 Installation And Disassembly Guide	17
4.1 Installation Steps.....	17
4.2 Disassembly Steps.....	17
5 Product Usage.....	18
5.1 Advance Preparation	18
5.2 Flight Planning	18
5.3 Equipment Installation.....	18
5.4 LiDAR Power On	19
5.5 Data Collection.....	19
5.6 LiDAR Power Off.....	20
6 Product Workflow	Error! Bookmark not defined.
6.1 TV540 Connection	21
6.2 TV540 Webpage Configuration.....	22
6.2.1 Manual Mode	23
6.2.2 AUTO Mode.....	27
6.3 LiDAR Status Check	29
6.4 Log Download	30

6.5	Authorization	31
6.6	Firmware Update	32
7	Data Copy Steps	Error! Bookmark not defined.
7.1	Disk Structure	33
7.2	Data Copy Tool from LP360.....	34
7.2.1	Disk Format (Clearing Storage Space)	40
7.3	USB Exit.....	41
7.4	Data structure	41
7.4.1	GPS.....	42
7.4.2	IMG.....	42
7.4.3	SCAN.....	42
7.4.4	TRACE	42
8	TV540 Authorization Guide.....	43
9	Additional Information	44
9.1	Important Notes	44
9.2	Product Transportation.....	44
9.3	Usage Tips.....	44
9.4	Storage Tips.....	45
10	Frequently Asked Questions	46
11	Appendix	47
11.1	Replace DJI M300/M350 Shock Absorbing dampeners.....	47
11.2	DJI M300/M350 Installation Steps.....	49
11.3	Installing TV540 On Other Platforms	51
11.3.1	How to measure Lever Arm Offset	51
11.3.2	How to generate a new TV540 profile in LP360	51
Support	55

1 Reading Tips

1.1 Symbol Description

-  **Forbid**
-  **Warning**
-  **Important notes**
-  **Operate & Using tips.**

1.2 Disclaimer

- The customer should use and maintain the equipment in accordance with the requirements of the manual. If the service life of equipment is affected due to improper use or maintenance, even broken, GEOCUE will not bear the relevant responsibility. All repairs and maintenance services resulting from this will be charged at standard prices.
- During transportation, if the equipment is damaged due to improper logistics operation, GEOCUE will not bear the relevant responsibility.
- During equipment use, if a customer disassembles and assembles the equipment without GEOCUE's suggestions & permission, resulting in damage, GEOCUE will not bear the relevant responsibility.
- Customer should use default batteries and accessories. The use of non-original accessories is not eligible for warranty; if an accident occurs, the manufacturer will not bear the corresponding responsibility.
- The M300 drone and Skyport interface mentioned in the appendix are products of DJI Innovations Co., Ltd., based in Shenzhen, China.

2 Usage Requirements

2.1 Environment

- For safety purposes: It is not recommended to use in rainy, snowy, or foggy weather. Also, the point cloud data will have more noise.
- It is not recommended to frequently use in dusty environments, which will affect the service life of equipment.
- It is strongly recommended to avoid exposure of devices and accessories to extreme temperatures. The environmental temperature must not be lower or higher than the specification temperature.
- When the equipment is transferred from a cold environment to a warm environment, water may condense on certain components inside the scanner. To avoid this, it is recommended to place the scanner in a sealed plastic bag before transferring. When the condensation is evaporated, then the sensor can be removed from the plastic bag.

2.2 Tips Before Using

- Check whether the laser glass is normal, if there is dust, please use the cleaning kit to clean it.
- Check whether the ports are clean and whether the pins are normal.
- Check whether the connecting cables are reliable and stable and that the GPS cable is stable and normal.

2.3 Tips During Usage

- When using, make sure that all cables and ports are connected correctly.
- After powered on, check whether the connection between remote controller and equipment is normal, and whether the status of tracking satellites and board are normal.
- Place equipment in an open sky area with a good GPS signal when powered on.
- If the buzzer sounds abnormally during the capture process, please immediately check whether the equipment status is normal.
- Before starting work, check the remaining capacity of the data memory card. If the remaining capacity is less than 10% or does not meet the current collection capacity requirements, the old data file(s) needs to be deleted in advance.
- Check whether the controller's laser parameter settings are correct. If not correct, please reset it again according to the project requirements.

2.4 Tips After Using

- After using, unplug the cable first, then place the equipment into equipment case and accessories into accessory case.
- During transportation, take care of the equipment and try to avoid bumps.

3 Product Description

TrueView 540 is a new generation of mid-range airborne LiDAR system launched by GEOCUE in partnership with CHCNAV. Based on the design concept of “strong penetration, high precision”, the TrueView 540 integrates high-performance LiDAR, high-precision inertial navigation and a full-frame camera. Sensor data download and processing are performed with LP360 processing software. This provides "high precision, high efficiency, and low cost" 3D data acquisition and complete processing solutions for customers in terrain surveying, engineering surveying, power line inspection and other industries.

3.1 Hardware Check List

Note: Please refer to the actual delivery list.

TV540 LiDAR system configuration list is shown below:

	Description	Model	Pcs
1	TV540 unit	TV540	1
2	TV540 transport container		1
3	USB3.0 to TYPE-C adapter cable		1
4	USB disk (32G)		1
5	Lens cleaning wipes		10
6	Lens cleaning air blower		1
7	Mount platform for M300 or TrueView Payload Adapter		1

3.2 Delivery of Equipment and Materials

Note: Please refer to the actual delivery list.

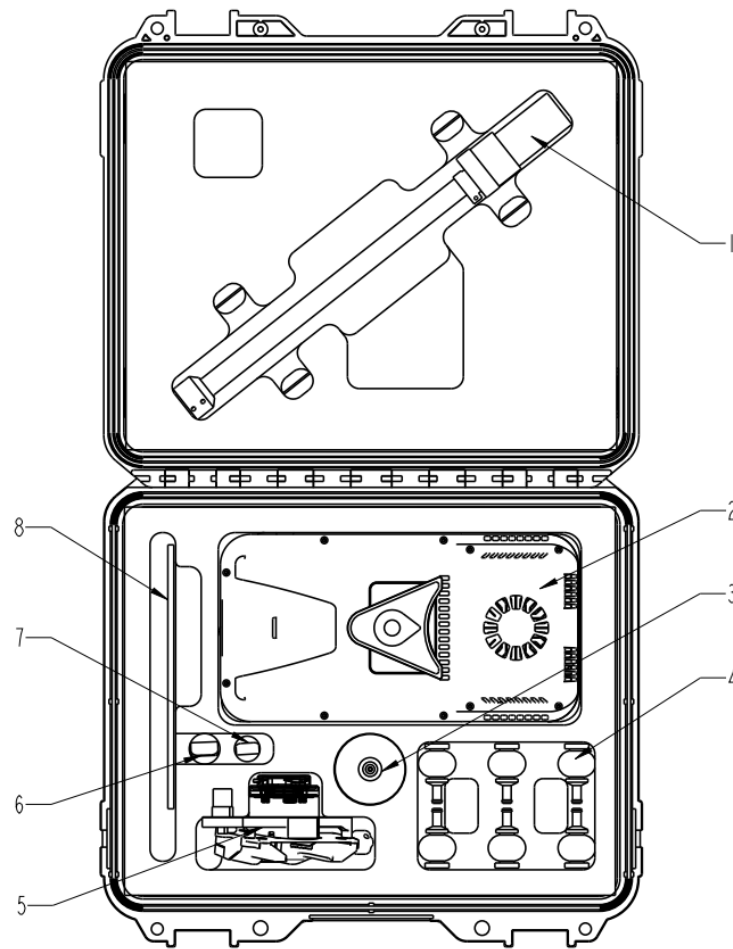

- | | |
|--|-----------------------------|
| 1. GNSS antenna | 5. Mount adapter |
| 2. TrueView 540 LiDAR system | 6. USB drive 1 |
| 3. Lens cleaning air blower | 7. USB drive 2 |
| 4. Shock absorbing dampeners for M300/M350 | 8. Supporting documentation |

- TrueView 540 LiDAR system:



- TrueView 540 transport container:



- Mount adapter and GNSS antenna:



- Lens cleaning air blower and cleaning wipes:



3.3 Physical Characteristics

3.3.1 Weight and Size

- Weight: 1.55kg.
- Length, width, and height (210×112×131mm):

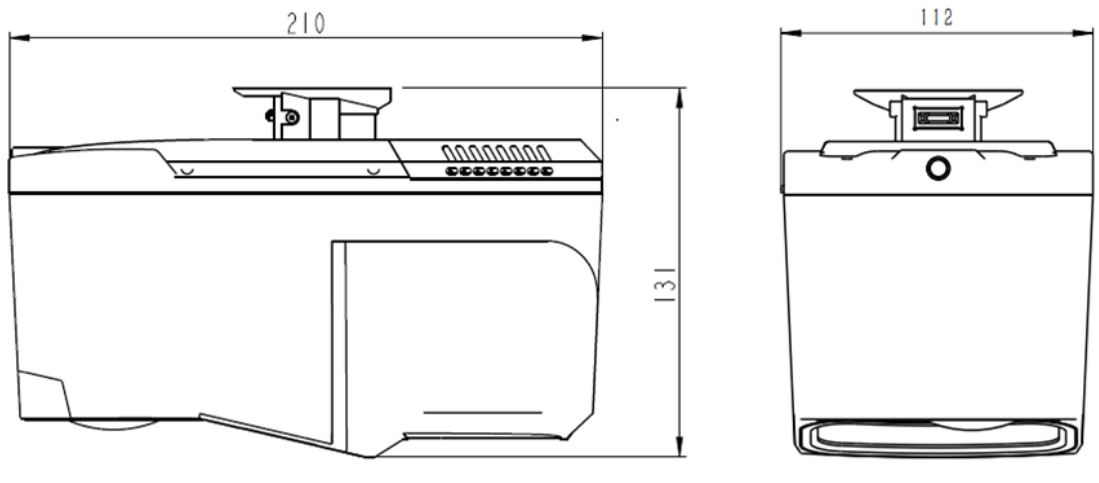

3.3.2 Interface Definition

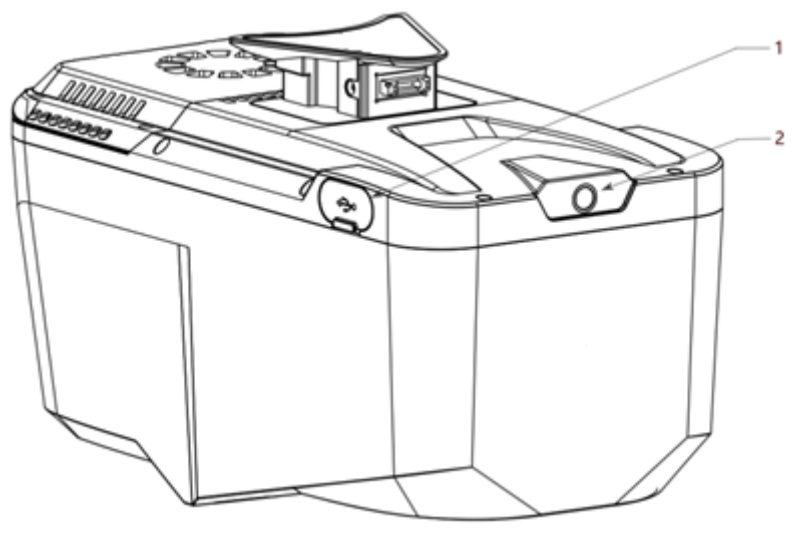

1. USB Type-C port for data copy.
2. LED indicator for device status.

LED indicator & buzzer	Device status
LED Indicator off	Power off
Quickly blink (5 times per second)	Under initialization
Solid	Initialization successful
Slowly blink (2 times per second)	Create project successfully; GNSS & IMU data collecting...
Normal blink (1 time per 2 second)	Data capturing...
Abnormal blink with sound	Abnormal status

3.4 Power Supply and Physical Characteristics

Power consumption	40W
Working temperature	-20 °C to +50 °C
Storage temperature	-20 °C to +60 °C

3.5 TV540 Technical Data

3.5.1 Laser Product Classification

Class 1 Laser Product according to IEC 60825-1:2014



3.5.2 Max. Measuring Range

Laser Pulse Repetition Rate PRR	100kHz	300kHz	500kHz
Max. range, @ $\rho >10\%$	283m	194m	152m
Max. range, @ $\rho >20\%$	400m	275m	215m
Max. range, @ $\rho >80\%$	800m	480m	280m

NOTE:

- Rounded values.
- Flat terrain assumed.
- Typical values for average conditions. Maximum range is specified for flat targets with size more than the laser beam diameter, perpendicular angle of incidence.

3.5.3 Max. Operating Flight Altitude AGL

Flat terrain assumed, scan angle 75° (± 38°) FOV

Laser Pulse Repetition Rate PRR	100kHz	300kHz	500kHz
@ $\rho >10\%$	224m	154m	121m
@ $\rho >20\%$	317m	218m	170m
@ $\rho >40\%$	449m	308m	222m
@ $\rho >60\%$	549m	378m	222m
@ $\rho >80\%$	634m	381m	222m

NOTE:

- Rounded values.
- Flat terrain assumed.
- Different target reflectance has different max. operating flight altitude AGL.

(1) When the mission area consists of post-rain scenes or mainly targets of asphalt materials, which have low reflectance, it is recommended to set the flight altitude with a reflectance $\rho >10\%$.

(2) When the mission area mainly composed of materials like deserts, limestone, etc., it is recommended to set the flight altitude with a reflectance $\rho >40\%$.

(3) For other general mission areas, it is recommended to set the flight altitude with a reflectance $\rho >20\%$.

3.5.4 Max. Operating Flight Altitude AGL & Point Density

The graph below shows the maximum operating flight altitude AGL at different Laser Pulse Repetition Rate PRR under different target reflectance.

The graph below also shows the relationship between the average point density within a single strip and the flight speed.

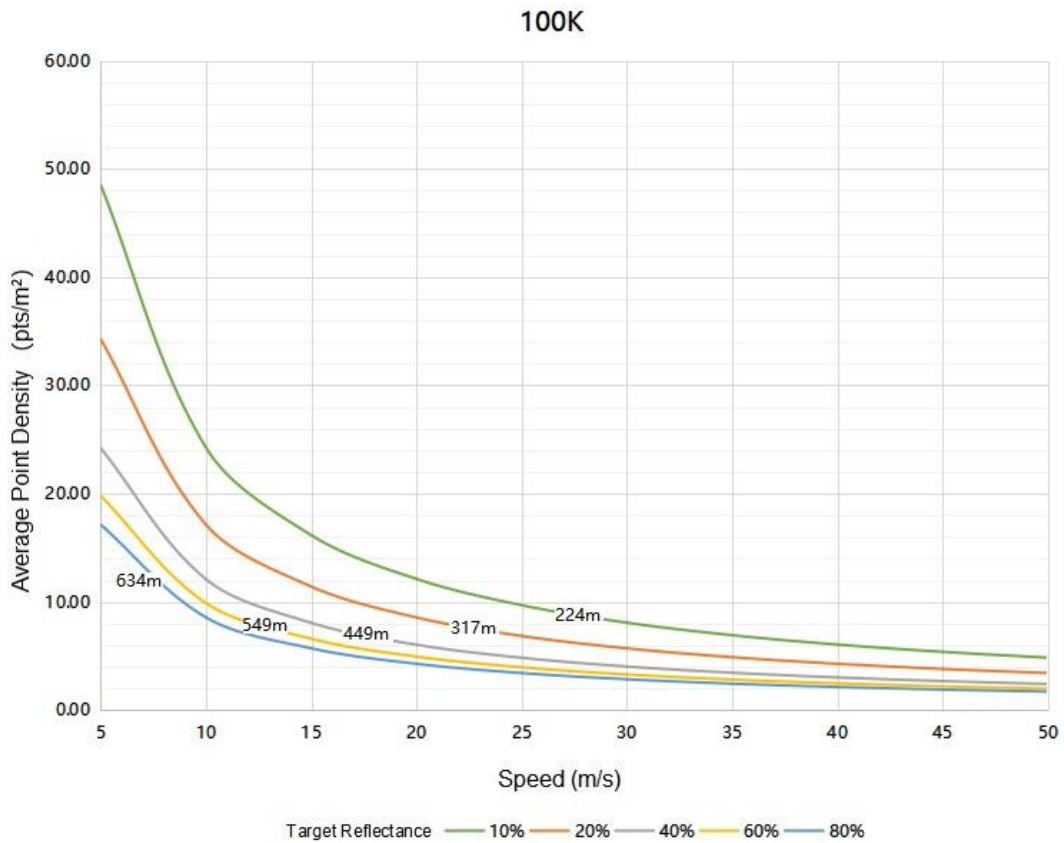

300k

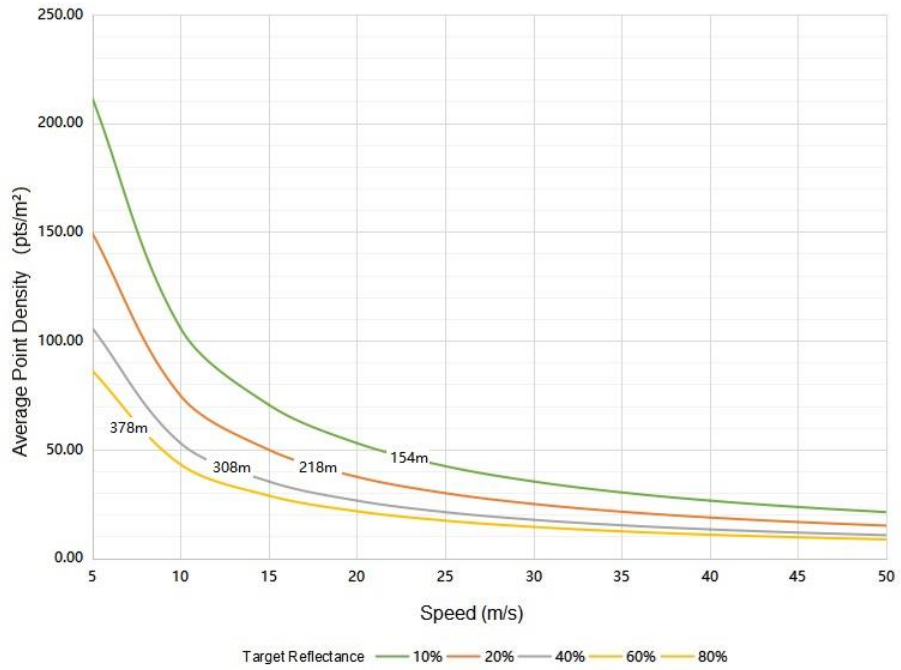

500k

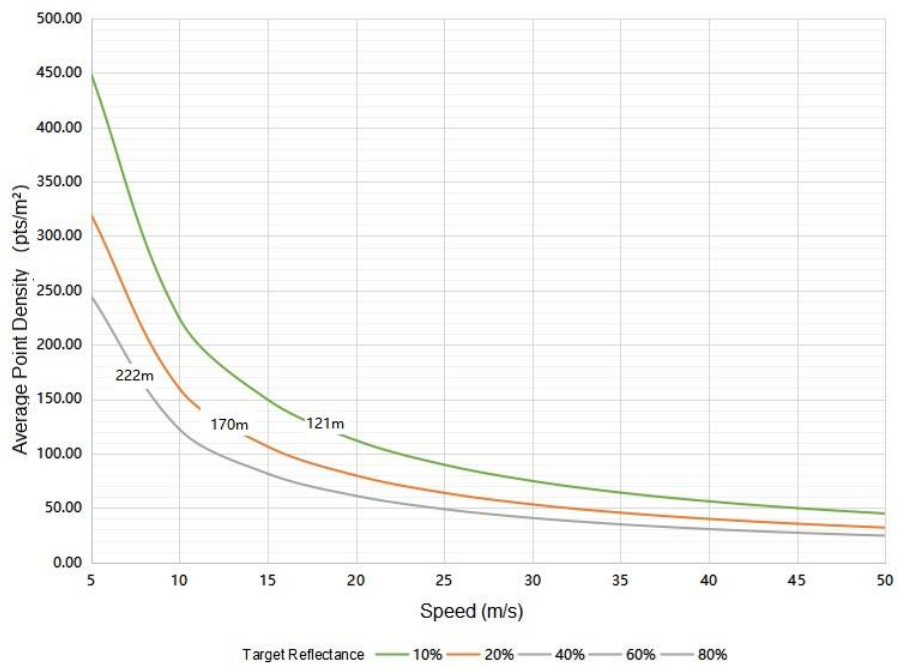

4 Installation And Disassembly Guide

4.1 Installation Steps

- Push the “Alphaport” slider of scanner into the quick-release clamp which is on the bottom of the airborne mounting platform in the direction of the arrow until the user hears a “click” sound.
- Tighten the side screw bolt to make it stable to complete the installation.
- Insert the rod antenna into the antenna mount and tighten it.

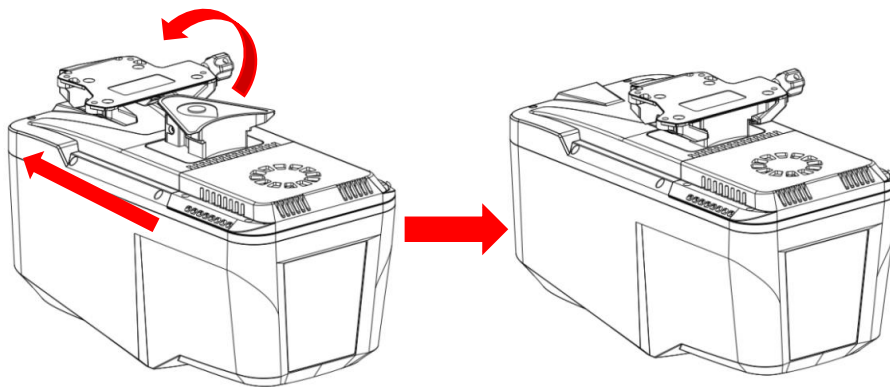

4.2 Disassembly Steps

- Unscrew rod antenna and remove.
- When removing the TV540 from the platform, hold the bottom of device with left hand, loosen the side screw bolt counterclockwise with right hand until the threaded part of the side screw bolt disengages.
- Pull the side screw bolt back to the maximum position with the right hand and keep the bolt in this position. Pull the “Alphaport” slider of scanner out the quick-release clamp which is on the bottom of the airborne mounting platform in the direction of the arrow.

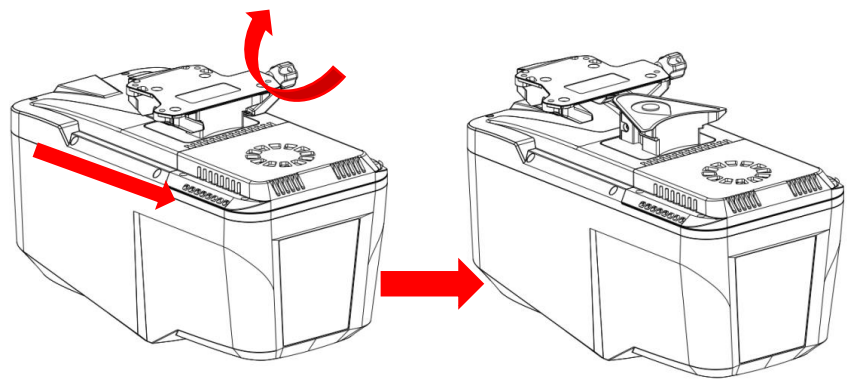

5 Product Usage

5.1 Advance Preparation

- Check the equipment to ensure that the contents and other accessories are not missing.
- Check whether there are any stains on the laser beam exit window and camera lens. If there are stains, use the cleaning tools provided with the package to gently wipe and clean them.
- Make sure the batteries of the base station, aircraft, and remote control are fully charged.
- Using the remote, check sensor authorization and storage space.
- Confirm whether there are tall buildings or interference sources near the take-off point.

5.2 Flight Planning

For flight planning, use the sensor Web UI to calculate flight line spacing and set the camera trigger interval and camera parameters. Enter the desired altitude, speed, sidelap and front lap and tap the Apply button. The required flight line spacing will be shown at the bottom of the screen. 80% frontlap is sufficient for most general applications, sidelap should be a minimum of 40%. The range of the sensor is dependent upon the settings used but generally exceeds the FAA altitude limit for sUAS. The practical range is 400m at >20% reflectivity.

Box Turns

At the end of each flight line, the drone will change headings and transition to the next flight line. To optimize accuracy, it's recommended to perform box-turns at the ends of flight lines. These are highly efficient turns that also keep the heading aligned. Some flight planning applications attempt to create rounded turns to avoid stopping and save time, but box-turns are better for IMU output. A box turn can be described as follows:

- At the end of a flight line quickly coming to a hover
- Rotate about the Down axis by +/-90 deg
- Accelerate to the start of the next line and come to a hover
- Rotate about the Down axis by +/- 90
- Accelerate and fly the next line

5.3 Equipment Installation

Take out the equipment from the container before using. Install on the corresponding platform, lock by tightening screw and connect all cables. For detailed information, refer to [Section 4.1](#) and for DJI M300/M350 – [Section 11.2](#)

5.4 LiDAR Power On

Set up the base station in an open sky area with recording frequency set at 1Hz (1 observation per second). Turn on the equipment after the base station starts recording static data.

GNSS Base Station Requirements:

- L1/L2 Support
 - At minimum: GPS and GLONASS constellations observed
 - RINEX Export (V2.11 or later.)
 - Coordinates of observation in Lat/Long/Elevation (Ellipsoid (m))
 - Input reference frame used for the base location (ETRS89/NAD83(2011)/ITRS2014/WGS84)
 - Antenna Height
 - Antenna Height measurement type
 - Manufacturer Model
 - 1Hz interval
 - The base station should be recording 15 minutes before the flight and 15 minutes additionally after landing.
 - Baseline length: The base station should be the closest possible to the flight area with a maximum distance not greater than 20 km.
-
- Wait for about ten seconds for the device's indicator light to start flashing. This means the system has powered on successfully and started initializing.
 - Use phone or tablet to search for the WIFI of TV540 and connect to the device. For detailed information, refer to [Chapter 6](#).
 - After powering on the TV540, wait around 1 minute until the device indicator light becomes steady on, indicating that the device initialization is complete.

 **Note: The correct procedure is to install the TV540 first and then power on the aircraft. The TV540 does not have an on/off switch; the TV540 will automatically power on when the aircraft is powered on. So, please make sure to install the TV540 before powering on the aircraft.**

5.4 Data Collection

- After power up, to begin data collection, the sensor needs to sit on the ground for 3 mins before takeoff to collect a brief static observation which is needed for trajectory processing. When the static collection is complete the sensor will beep to indicate it is ready to fly.
- The sensor has a proximity zone feature that will begin (assuming that the user is utilizing Auto mode) and end based upon altitude and vibration. This can be changed to manual start/stop within the WebUI, but it is recommended to use proximity (Auto) mode.

- Because the DJI M300/M350 integration makes the aircraft front heavy, it is recommended to take off briskly, a slow take-off could potentially cause rocking and damage the sensor or aircraft. Once the aircraft is in the air and stable, perform a center of gravity calibration through DJI Pilot in a wind free environment to ensure the aircraft is balanced with the payload.

Additional Center of Gravity Instructions for DJI Platforms:

- Launch the DJI Pilot application, open a mission, or go into the manual view.
 - Tap the Ellipsis menu (...) on the top right corner of the screen.
 - Stay within the Flight Controller Settings tab and scroll to the bottom of this screen.
 - Tap the Center of Gravity Auto Calibration Button and follow the instructions.
- The heading alignment calibration should be a single figure eight maneuver at around 5 m/s (11mph) before the flight plan is executed and prior to landing.

▪The data streams are written in real time to the sensor’s internal 1 TB storage drive so no waiting is needed. Once the aircraft lands, allow it to collect static data again for 3 minutes until a beep is heard. The sensor is then ready to power cycle with the aircraft for more flights.

Basic flight operations overview/summary:

1. Set up the sensor on the drone.
2. Power on the drone.
3. Wait 3 minutes while the TV540 initializes, you will hear a beep once it is ready.
4. Take off.
5. Perform heading alignment maneuver, with figure-8 pattern at 5m/s.
6. Start the mission.
7. Finish the mission.
8. Perform the head alignment maneuver again (figure eight).
9. Land.
10. Wait 3 minutes for the sensor to wind down. You will hear a beep once it finishes.
11. Power off the drone.

5.6 LiDAR Power Off

- Before powering off equipment, please make sure the project recording has stopped.
- Turn off the power supply of the drone platform to power off the equipment.

 **TV540 has no “ON/OFF” button, which will be powered off automatically after the drone platform power supply has been turned off.**

6 Product Workflow

TrueView 540 uses a webpage-based user interface to configure settings and control. The webpage can be accessed from any computer, tablet, or mobile browser.

6.1 TV540 Connection

After TV540 installation is completed, turn on the drone's power. The TV540 will power on automatically, wait for about ten seconds, and the device's indicator light will start flashing, which means the system has powered on successfully and started initialization.

TV540 WiFi will be available which is named "TV540-xxxxx" (where "xxxxx" represents the last five digits of the device's serial number). Once connected to the device, scan the QR code located in the middle of the TV540 device box (see the figure below). It will login to the control web page of TV540. Users can also enter the web address "192.168.100.100" in the mobile phone's (also laptop or tablet) browser to access the control interface of TV540.

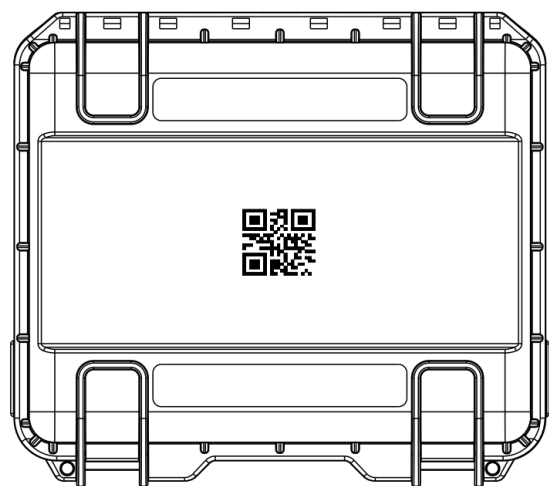

 **Note:** When connecting to the device using the mobile phone's Wi-Fi function, if the webpage is not allowed to access, 4G or 5G data mobile data connection may need to be disabled.

After powering on the TV540, wait around 3 minutes until the device indicator light becomes solid green, which means the device initialization is complete.

 **Note:** The correct procedure is to install the TV540 first and then power on the aircraft. The TV540 does not have an on/off switch; the TV540 will automatically power on when the aircraft is powered on. So, please make sure to install the TV540 before powering on the aircraft.

6.2 TV540 Webpage Configuration

 Please refer to the software interface.

The webpage interface is displayed as follows:

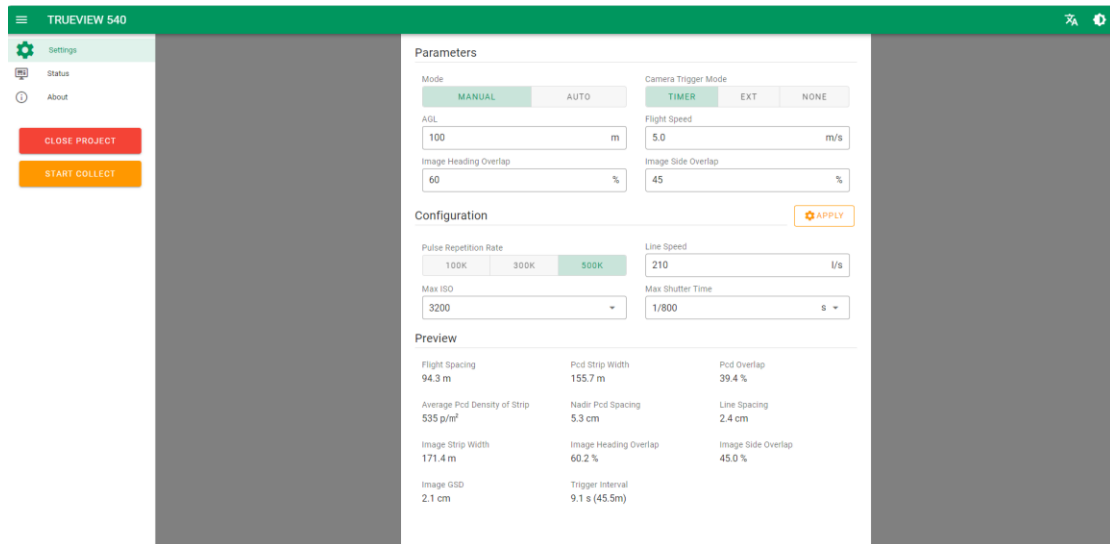

Manual mode interface

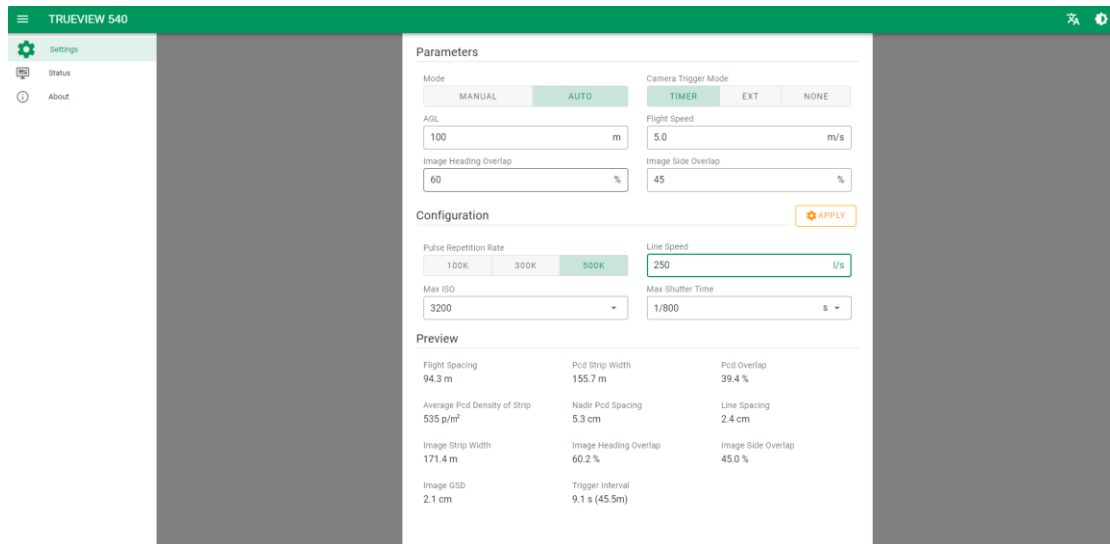

Auto mode interface

The operation mode of TV540 has two options: Manual mode and Auto mode. Users can switch between "manual" and "auto" modes.

6.2.1 Recommended Flight Parameters

Sensor power is provided through integration kit, the sensor does not have a dedicated power switch but is instead turned on and off when the aircraft is powered. The sensor does not have a built-in battery compartment. Once the integration kit is installed and the aircraft is powered on the sensor can be monitored and settings altered through the sensor's Web UI. To connect to the Web UI, use a phone, tablet, or computer to connect to the sensors Wi-Fi, no password is needed. Then open a web browser and go to the address 192.168.100.100. Refer to [Section 6.1](#).

1. Set up the sensor with the drone platform.
2. Switch on the drone.
3. The sensor will switch on automatically, wait 3 minutes while the sensor initializes.
4. The sensor will beep once is ready to fly.
5. Connect to the sensor Wi-Fi, network (Example: TRUEVIEW540-0000F).
6. Access to the web UI, site 192.168.100.100.
7. Select (Example of recommended common parameters):
 1. *Parameters*
 - A. Mode → AUTO
 - B. Camera trigger mode → TIMER.
 - C. AGL → input desired height.
 - D. Flight Speed → 5 m/s.
 - E. Image Heading Overlap → 80%.
 - F. Image Side Overlap → 40%.
 2. *Configuration*
 - A. Pulse Repetition Rate → 500K.
 - B. Line Speed → 250 m/s.
 - C. MAX ISO → 3200.
 - D. Max Shutter Time → 1/500s.
 - E. Click → APPLY.

6.2.1 Manual Mode

The default setting is manual operation mode. However, this is not the recommended mode. We recommend switching to AUTO Mode. Please refer to the [AUTO Mode \(proximity mode\) section](#). In case the manual mode is still needed, the specific workflow is as follows:

1. Configure the "Camera Trigger" option first. There are three camera trigger modes: TIMER, EXT and NONE. The default operation mode is "TIMER". This setting is recommended as the external signal trigger is not supported in this product version integration.

Available Camera Trigger Modes and Related Settings:

- Timer: Camera takes pictures by time interval. The minimum interval is set to 1s.
- Trigger param (s) = (1-camera heading overlap) * GSD (m) * 5460/flight speed (m/s).
- GSD (m) = AGL (m) * pixel size (mm) / focal length (mm).
- External: Camera takes pictures by external signal trigger.
- None (Disabled): Camera will not take pictures.

Parameters

Mode

MANUAL

AUTO

Camera Trigger Mode

TIMER

EXT

NONE

2. When the camera is enabled, the user needs to input AGL, flight speed, image heading overlap and side overlap in relation to project conditions and data requirements. When the camera is disabled, the user will only need to input AGL and flight speed information.

3. After the parameter settings are completed, in the "Configuration" section, the software automatically calculates and sets the recommended pulse repetition rate and line speed based on input parameters such as AGL and flight speed.

4. After clicking "Apply", the settings of pulse repetition rate and line speed will be implemented.

AGL

m

Flight Speed

m/s

Image Heading Overlap

%

Image Side Overlap

%

Configuration ⚙️ APPLY

Pulse Repetition Rate

100K

300K

500K

Line Speed

l/s



Note: When there is strong wind, the flight attitude of the drone may become unstable, resulting in different laser scanning lines in each strip. In this case, the user can manually adjust the line speed to a value higher than the recommended value to achieve a more uniform point cloud. Users can also modify the pulse repetition rate and line speed according to the specific conditions of the project. The line speed can be set within the range of 50-250 l/s.

5. When the camera is enabled, set "Max ISO" and "Max Shutter" in the "Configuration" section. ISO and shutter speed will automatically adjust within their set maximum range based on the brightness of the scene.

Configuration
⚙️ APPLY

Pulse Repetition Rate

100K
300K
500K

Line Speed

250
l/s

Max ISO

3200
▼

Max Shutter Time

1/800
s ▼

Note: Mounting on rotor-wing UAV: set "Max ISO" to 3200 and "Max Shutter" to 1/800.

Mounting on Fixed-wing UAV: set "Max ISO" to 3200 and "Max Shutter" to 1/1000.

6. After configuring the relevant parameters, in the "Preview" section, you can view the following details:

Preview

Flight Spacing 94.3 m	Pcd Strip Width 155.7 m	Pcd Overlap 39.4 %
Average Pcd Density of Strip 535 p/m ²	Nadir Pcd Spacing 6.3 cm	Line Spacing 2.0 cm
Image Strip Width 171.4 m	Image Heading Overlap 60.2 %	Image Side Overlap 45.0 %
Image GSD 2.1 cm	Trigger Interval 9.1 s (45.5m)	

7. Once the parameter settings are completed, click on "New Project". The indicator light on the device will change from a solid green to slowly blink for IMU static alignment. Do not move the drone platform/sensor for at least 3 minutes during the slow blink status.

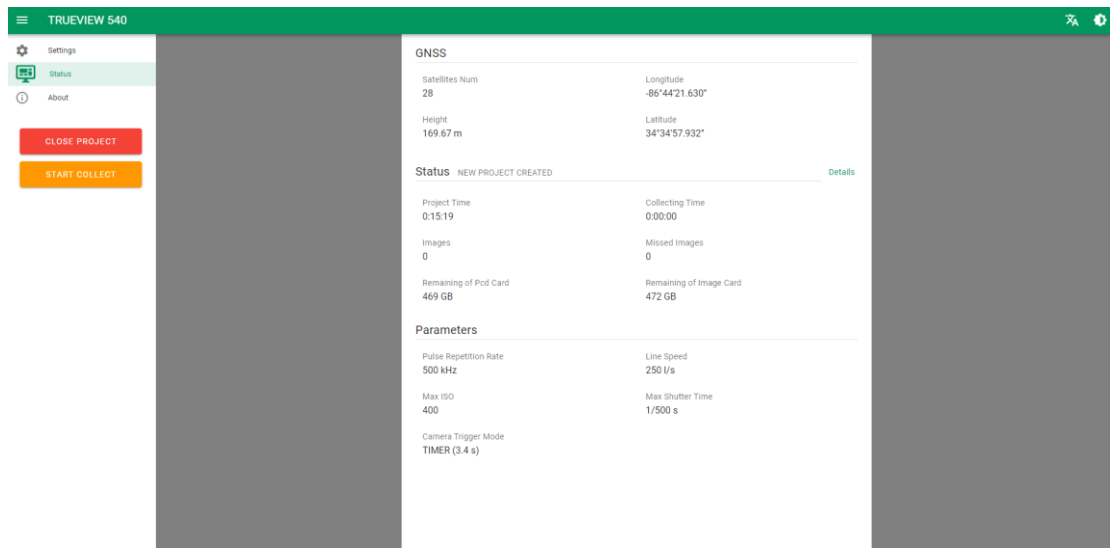

8. After 3 minutes of slow blink, click on "Start Collect", the indicator light on the device will change to quickly blink, which means TV540 starts capture data. After that, the user can control UAV to take off and start mission.

9. After completing a single flight mission, the UAV will return and land. Connect to TV540 Wi-Fi and login to webpage. Click on "Stop Collect" to stop data capture. The indicator light will change to slowly blink again. Do not move the drone platform/sensor for at least 3 minutes during the slow blink status.

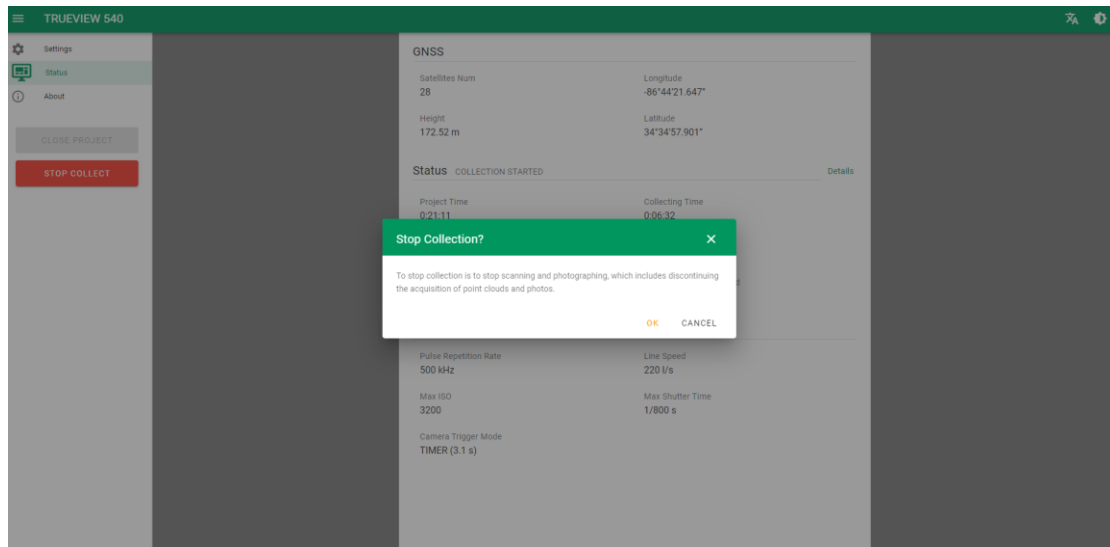

10. After 3 minutes static observation, click on "Close Project", and the indicator light will change to solid green, which means project stop & save successfully.

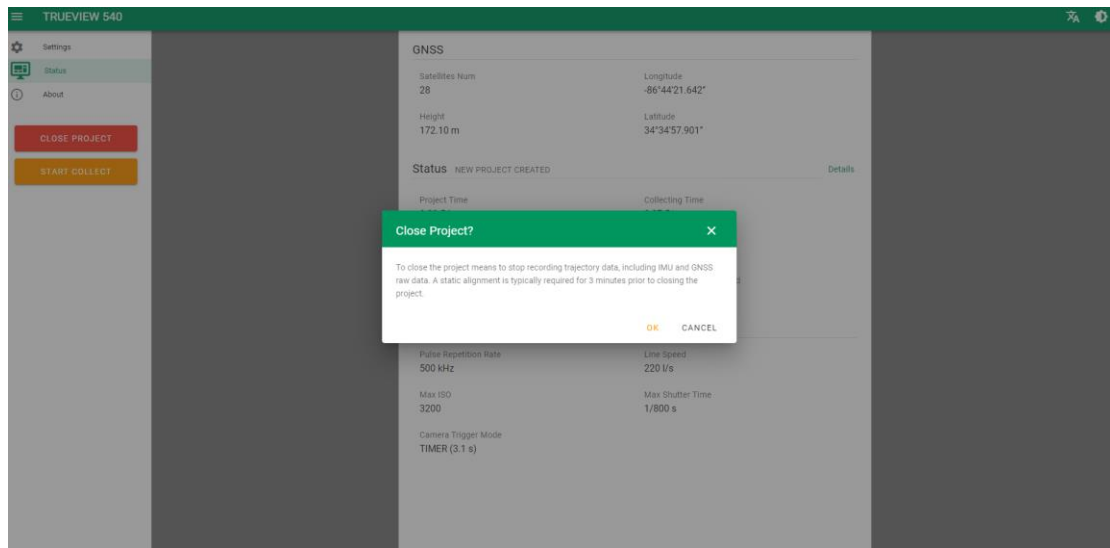

11. Turn off the power of the UAV and the device will automatically shut down.

Note: The device supports saving configuration parameters. After power off and restart, the default settings will be the same as the last configured parameters.

6.2.2 AUTO Mode

TV540 also supports AUTO mode which allows automatic flight collection start and stop. This is the recommended mode for data collection. The workflow is as follows:

Steps:

1. Click on the "AUTO" button to switch to automatic operation mode.

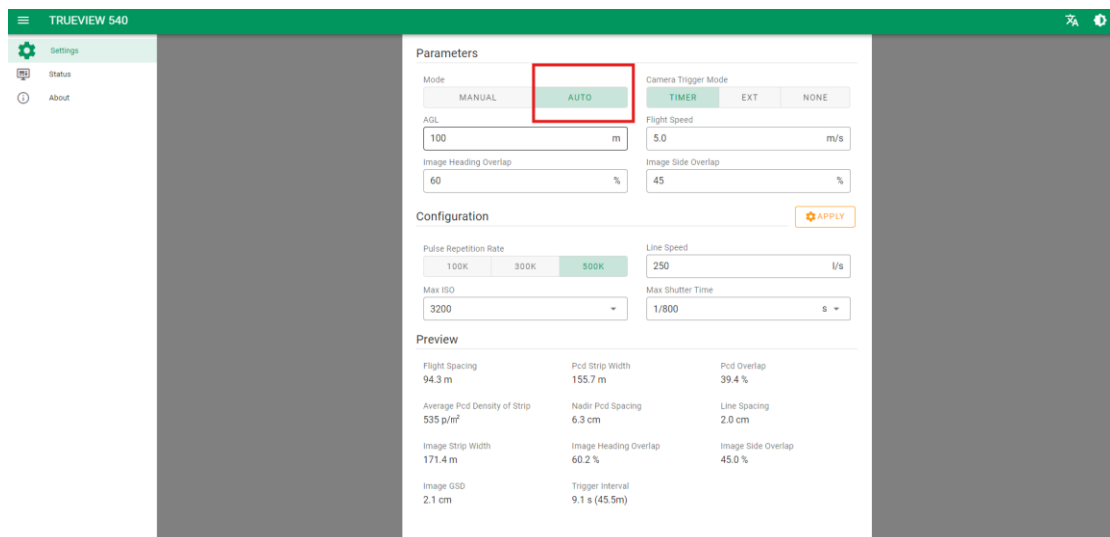

 **Note:** After switching to "AUTO" mode, the "New/Close Project" and "Start/Stop Collect" buttons will disappear.

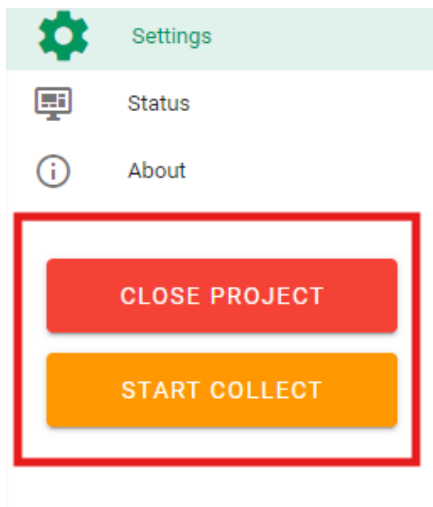

"MANUAL" mode

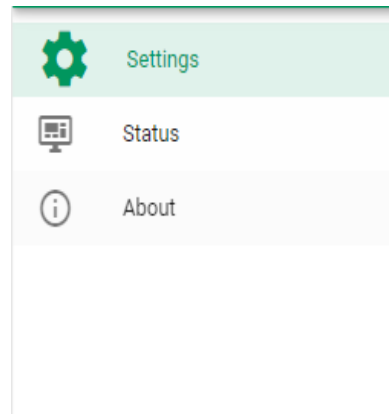

"AUTO" mode

2. After the device initialization is complete, a new project will automatically be created. At this time, the indicator light on the device will change from a solid green to slowly blinking.

3. Regarding parameter settings, the method for setting parameters in automatic mode is the same as in manual mode (reviewed in the previous [Section 6.2.1](#)). After 3 minutes of static observation (leaving drone platform stationary on the ground), the TV540 buzzer beeps for 1 second, indicating that the user can perform the aerial surveying mission.

4. During takeoff, the TV540 sensor automatically starts data collection by detecting its own vibration status. At this time, the indicator light of the device will quickly start blinking.

5. After completing a single flight mission, the UAV will return and land. The device automatically stops data collection by detecting its own vibration status when static for more than 5 seconds. At this point, the indicator light of the device changes to slow blink. Keep the drone stationary on the ground for another 3 minutes for IMU static alignment.

6. After 3 minutes, the TV540 buzzer beeps for 1 second, indicating that the user can power off the device.

7. If multiple missions need to be performed at the same takeoff point, and the drone supports hot swapping of batteries without power interruption, user can directly perform the next mission after replacing the drone battery. In this case, when the device detects vibration, it will automatically start data collection for the next mission.

 **Note:** After data collection is completed in "AUTO" mode, you can also manually switch to the "Manual" mode to close the project.

6.3 LiDAR Status Check

Users can check TV540 LiDAR status on the webpage: GNSS, status, and parameters. Click the  icon on the top-left corner of the webpage and then click the "Status" button to switch to the status check interface for viewing.

GNSS Interface: This section displays the number of satellites and positioning information.

Status Interface: This section displays the project details.

- Project Time: The total time from initial project creation.
- Collect Time: The total time of data captured.
- Images: Total captured photos number.
- Missed Images: The number of photos missed during the data collection.
- Remaining of Pcd Card: Available storage space on the point cloud storage card.
- Remaining of Image Card: Available storage space on the image storage card.

Parameters Interface - This section displays the project parameters:

- Pulse Repetition Rate: The project used PRR settings.
- Scan Speed: The project used scan speed.
- Max ISO: The maximum ISO value set for the camera.
- Max Shutter: The maximum shutter for the camera.
- Camera Trigger: The time interval for the camera pictures.

Users can easily access and view this information by clicking the "Status" button after clicking the icon on the top-left corner of the webpage.

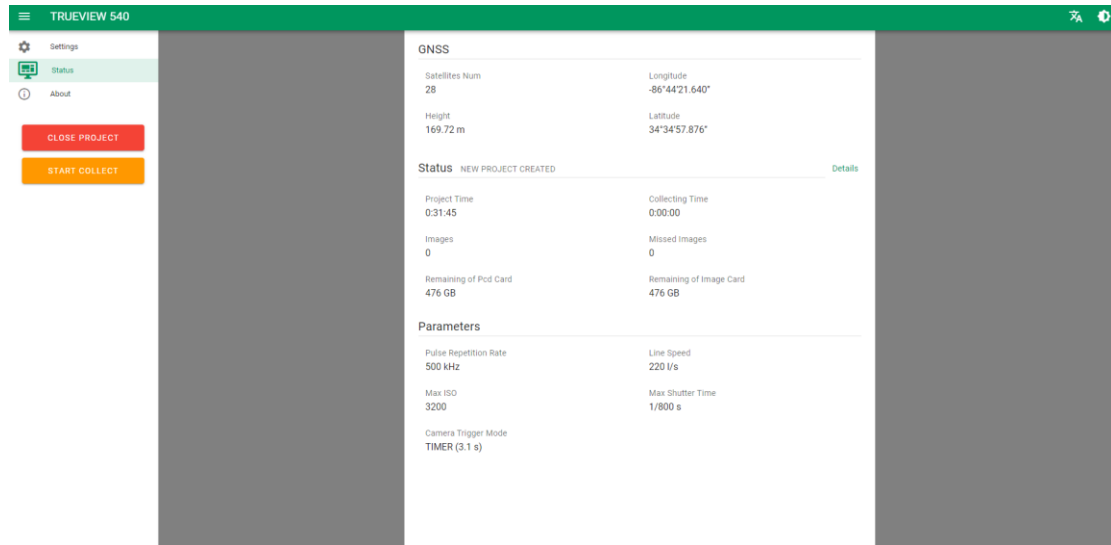

Click "Details" will display the current status of "System", "GNSS", "LiDAR", "IMU" and "Camera".

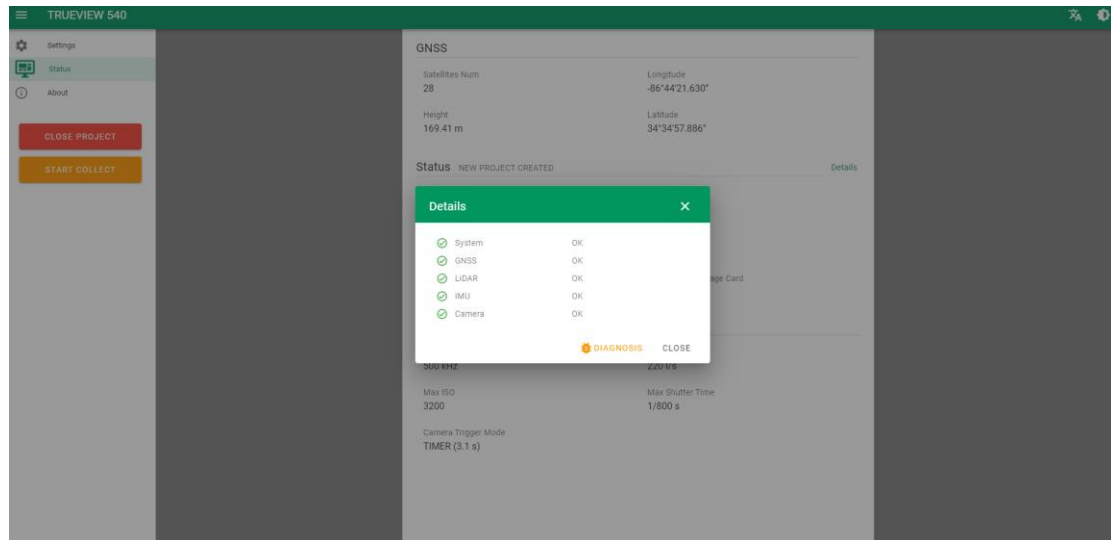

6.4 Log Download

When the device encounters an abnormal situation, it will be displayed in red on the software interface. In the "Details" section, user can view the reason for the abnormality, which will be indicated by a red exclamation mark (!) as a warning sign.

If the TV540 unit cannot be operated properly, user can download a diagnostic report from the "Details" section and send it to the GeoCue support team for analysis. Here are the steps to download the diagnostic report:

1. Go to the "Details" section of the software interface.
2. Click on the "Diagnosis" option.
3. Select the desired date for which you want to generate the diagnostic report.
4. Click on the "Download" button.

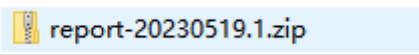

6.5 Authorization

The "About" interface displays the device's Serial Number (SN), Part Number (PN), Firmware Version Number, and the expiration date of the authorization. If the LiDAR expired, please contact the GeoCue support team.

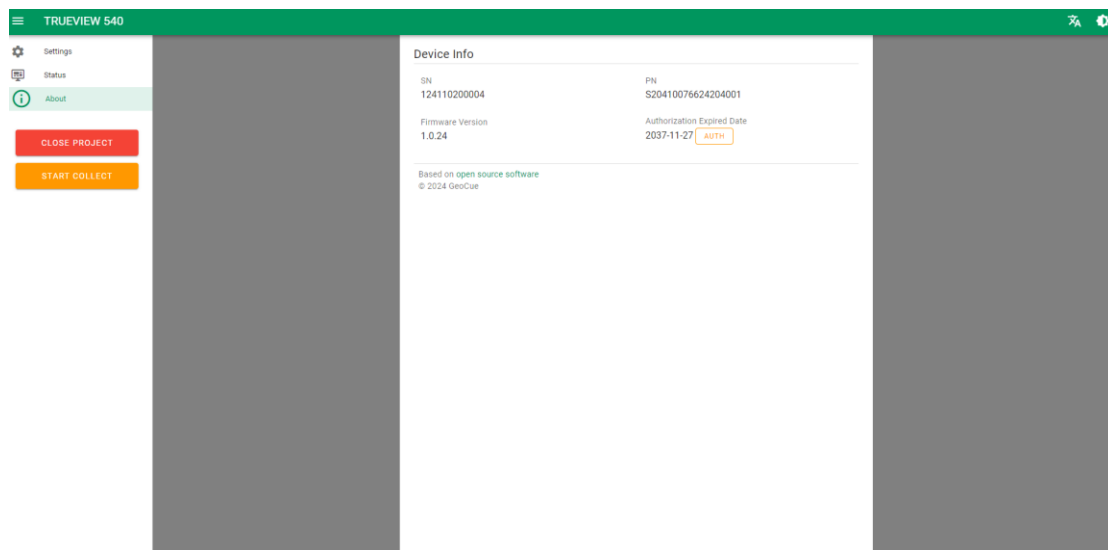

6.6 Firmware Update

Firmware can be acquired through GeoCue Support. Prepare the TV540 for update by performing the following steps:

1. Download the firmware (contact GeoCue support for the latest firmware download).
2. Connect the sensor via the supplied USB-A to USB-C cable.
3. In File Explorer, copy the firmware update file (Example: "update_aa10_v1.1.0_b20240607.bin") to the sensor disk drive: "ALPHA_SYS".
4. Mount the sensor to the drone
5. Power on the drone.
6. The sensor will take 15 minutes to install the firmware update. During that time, the light will blink 5 times per second. It will beep once after it finishes.
7. Power down the drone.
8. Switch on the sensor--> Web UI--> Check the firmware version to confirm successful firmware update.

7 Data Copy Steps

Connect the TV540 to the computer with the type-C cable, the computer will pop up two disks: ALPHA_SYS contains laser data, GNSS & IMU data, and ALPHA_CAM contains picture data.



 **Note:** Connect the TV540 to the computer with the type-C cable when the device is powered off. Otherwise, the SD card (data storage card) cannot be recognized.

7.1 Disk Structure

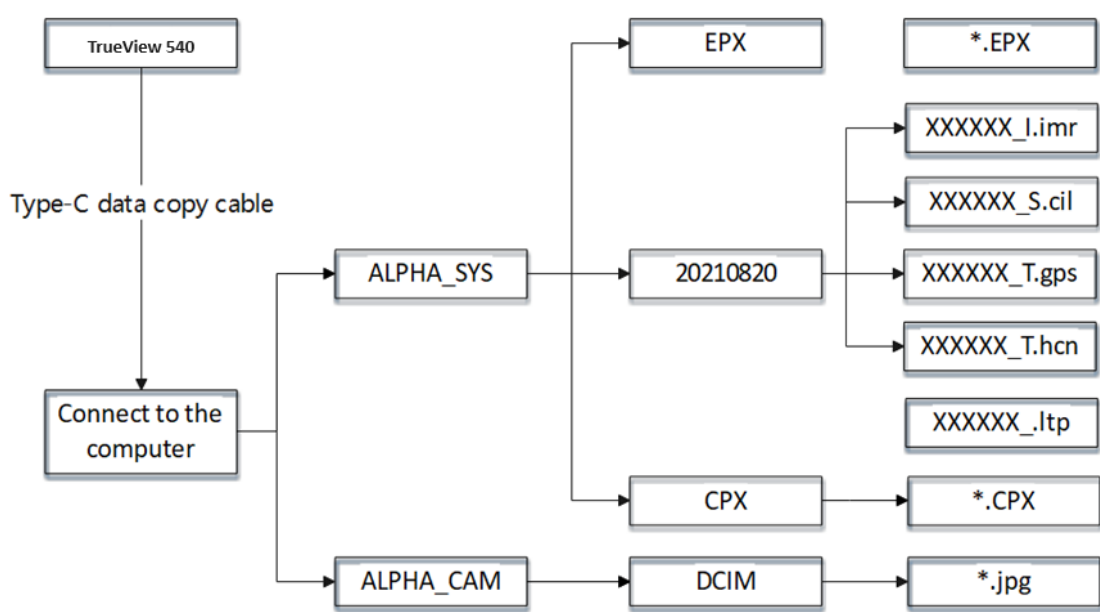

- ALPHA_SYS: Both laser & GNSS & IMU data are recognized based on capture date. For example: “20210820” means the data was collected on August 20, 2021.

xxxxxx.ltp: Laser data.

xxxxxx_I.imr: IMU data.

xxxxxx_S.cil: Synchronizes data.

xxxxxx_T.gps/ xxxxxx_T.hcn: GNSS data.

*.EPX: Laser calibration file.

*.CPX: Camera calibration file.

- ALPHA_CAM: Store picture data.

Note:

- *.EPX & *.CPX: Default calibration files which cannot be modified or deleted.
- Please do not delete or manually format disks, otherwise it will affect data copy. Users can find a backup parameter folder on USB disk if the disk folder has been deleted.

7.2 Data Copy Tool from LP360

Users need the TV540 data copy tool from LP360 software to automatically copy raw data from the device to PC: [LP360 Drone Users Guide – TV540 Data Copy Link](#)

Steps:

- Connect the TV540 to a computer with the type-C cable and 2 disks will populate: ALPHA_SYS and ALPHA_CAM.



- Click “Tools - Data Copy”:

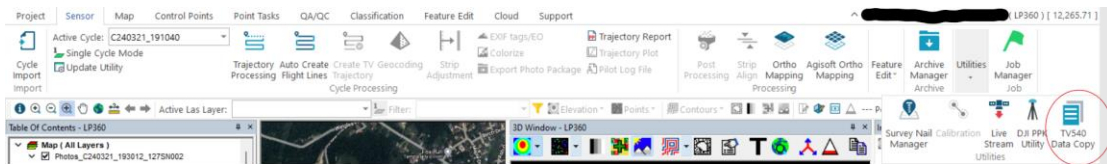

- Choose the correct device from “Module1” list, then select projects from left list and click “Settings”.
- Finally, click “Finish”.

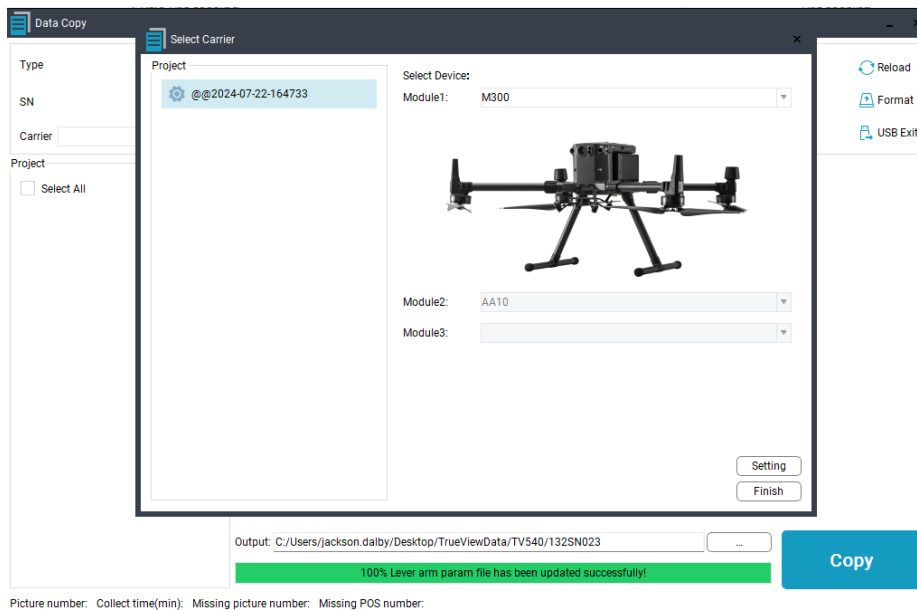

- The data copy tool will read LiDAR type and SN on left top corner.

Data Copy

Type AA10

SN 124110200004

Carrier UAV_M300

Project

Select All

@@2024-07-22-164733

SYSTEM 476.58GB is available
LIDAR 476.58GB is available
CAMERA 476.60GB is available
Reload

Stored: 17,can store: 170626
Format
USB Exit

Camera
Scanner
POS

ID	File Name	File Size	Modification Date	File Description
1	20240722_170557_000.itp	47.00KB	2024.07.22 17:06:53	Scanner_LT

Output: C:/Users/jackson.dalby/Desktop/TrueViewData/TV540/132SN023
...
Copy

100% Match project data finished.

Picture number: 17 Collect time(min): 29.2 Missing picture number: 0 Missing POS number: 0

- Users can check project data folders of the device in the data column on the left. Select one or multiple sets of data, then it will display corresponding camera pictures, laser, and GPS data on the right side.

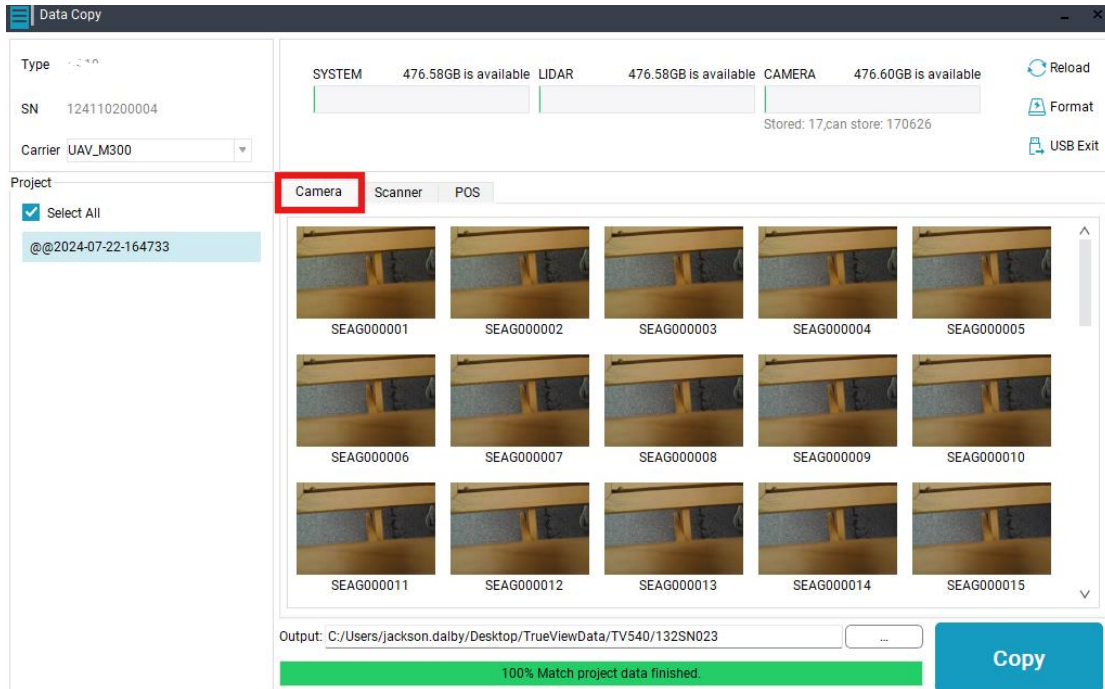

Picture number: 17 Collect time(min): 29.2 Missing picture number: 0 Missing POS number: 0

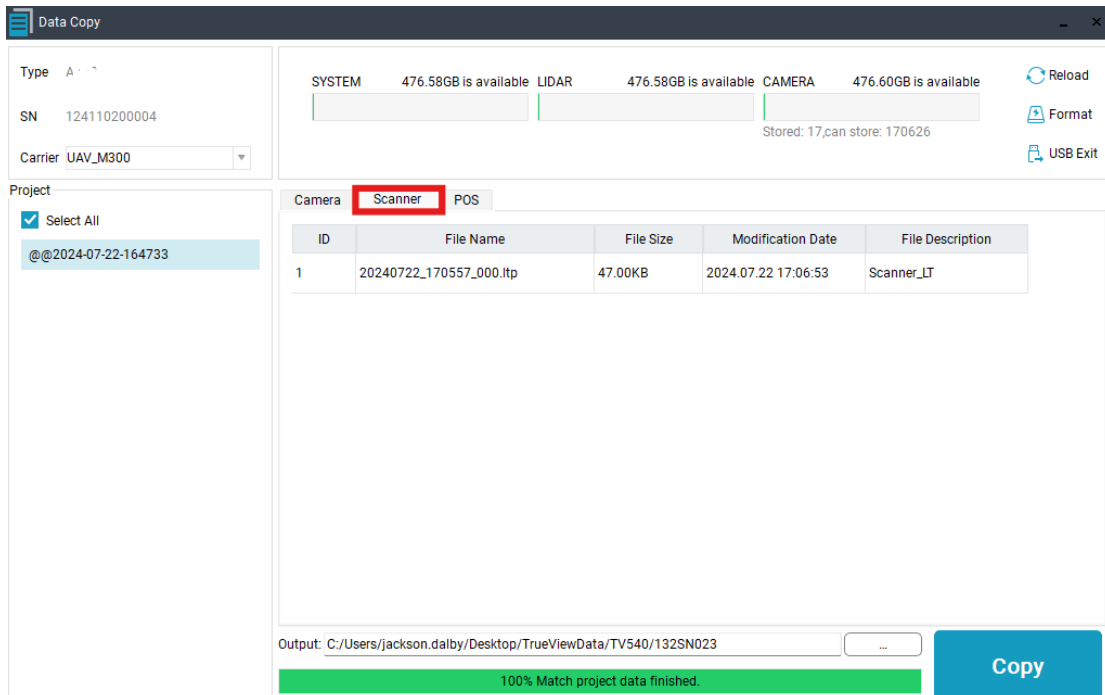

Picture number: 17 Collect time(min): 29.2 Missing picture number: 0 Missing POS number: 0

Data Copy
Close

Type

SN 124110200004

Carrier UAV_M300

SYSTEM 476.58GB is available | LIDAR 476.58GB is available | CAMERA 476.60GB is available

Stored: 17, can store: 170626

Reload

Format

USB Exit

Project

Select All

@@2024-07-22-164733

ID	File Name	File Size	Modification Date	File Description
1	20240722_164733_S.cil	165.00KB	2024.07.22 17:16:50	Camera Trigger Data
1	20240722_164733_D.dmr	27.00KB	2024.07.22 17:16:50	Encoder Data
1	20240722_164733_I.imr	26.79MB	2024.07.22 17:16:50	Inertial Sensor Data
1	20240722_164733_T.gps	21.36MB	2024.07.22 17:16:50	Mobile Station Data
1	20240722_164733_T.hcn	21.37MB	2024.07.22 17:16:50	Mobile Station Data

Output: C:/Users/jackson.dalby/Desktop/TrueViewData/TV540/132SN023

Copy

100% Match project data finished.

Picture number: 17 Collect time(min): 29.2 Missing picture number: 0 Missing POS number: 0

 **Note:** Select one or multiple sets of data needed to copy with Ctrl and Shift shortcuts.

 **Note:** Double-click on a photo to view details.

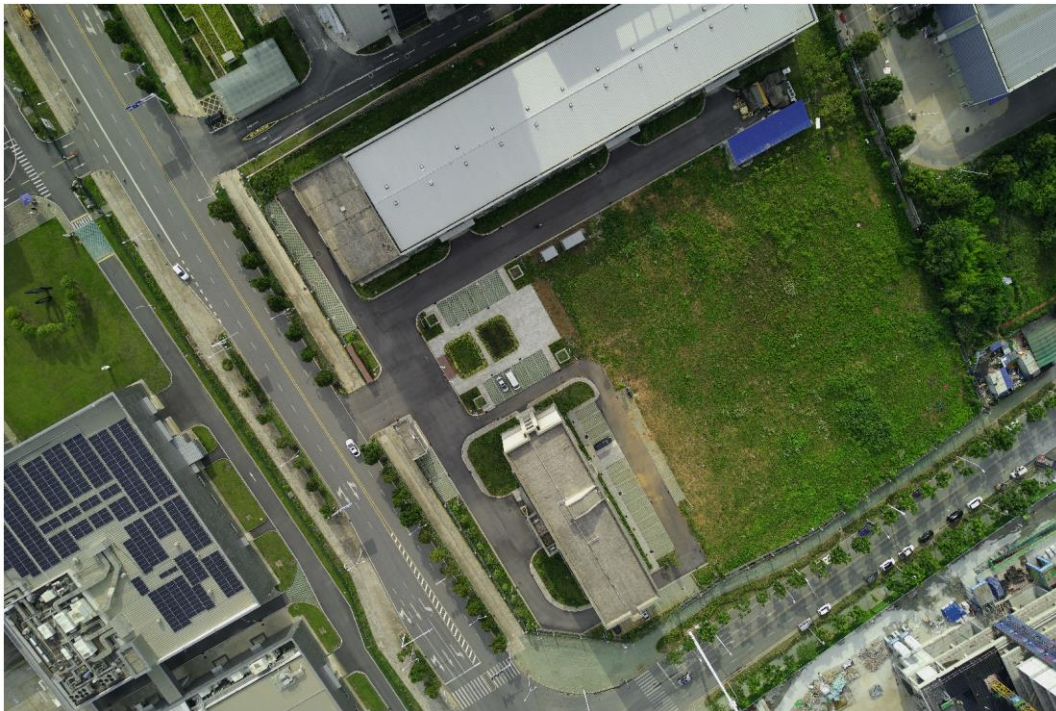

- Define an output path to store project data.

Picture number: 148 Collect time(min): 10.9 Missing picture number: 0 Missing POS number: 0

- Click “Copy” and it will automatically copy selected data projects.

Picture number: 17 Collect time(min): 29.2 Missing picture number: 0 Missing POS number: 0

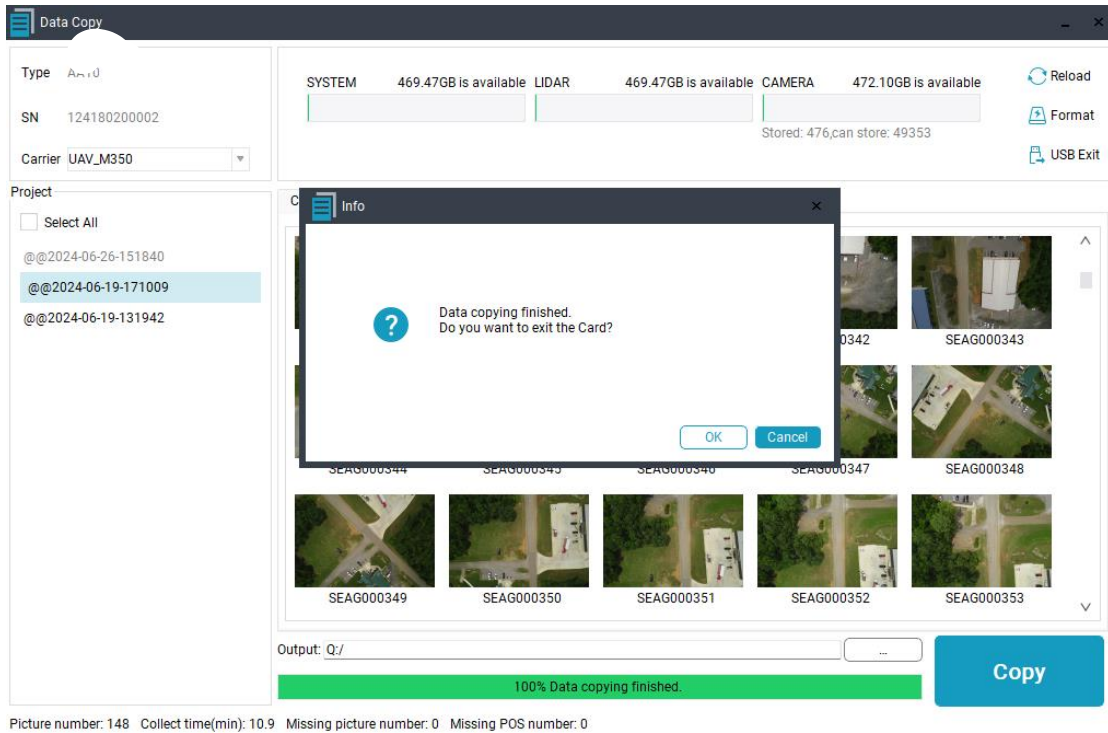
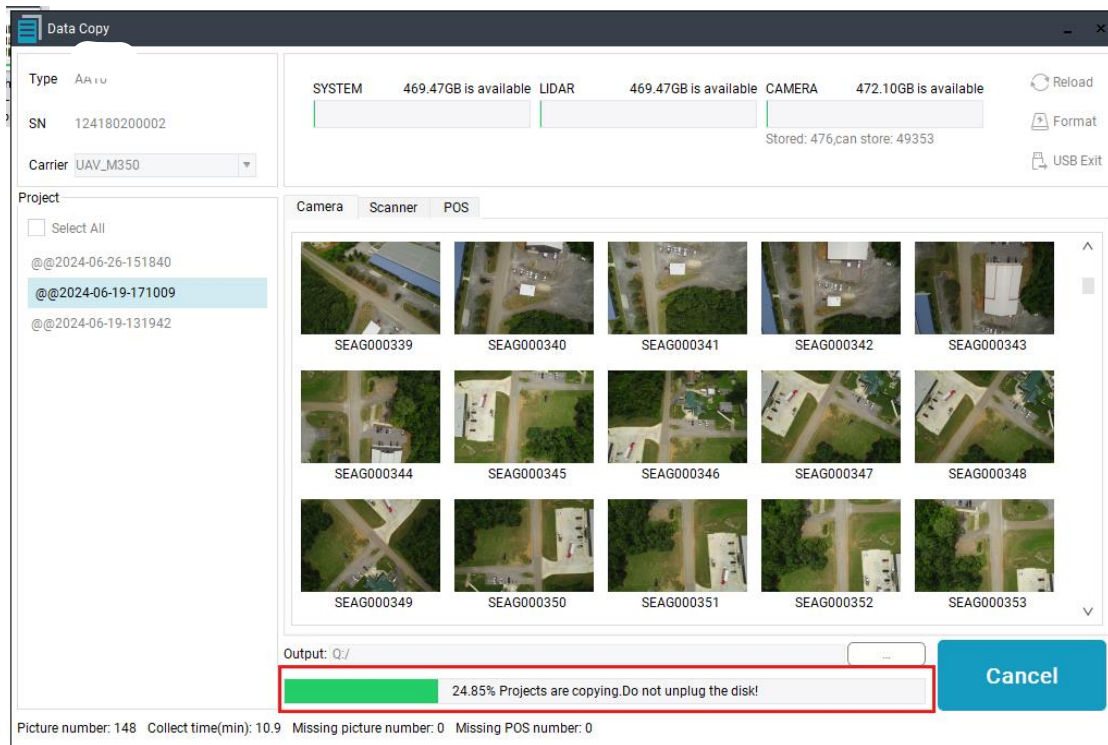

7.2.1 Disk Format (Clearing Storage Space)

If the disk storage space is insufficient, user can click “Format” icon on the upper right corner to format the disk. This format will only delete project data, but not delete default parameter folder.

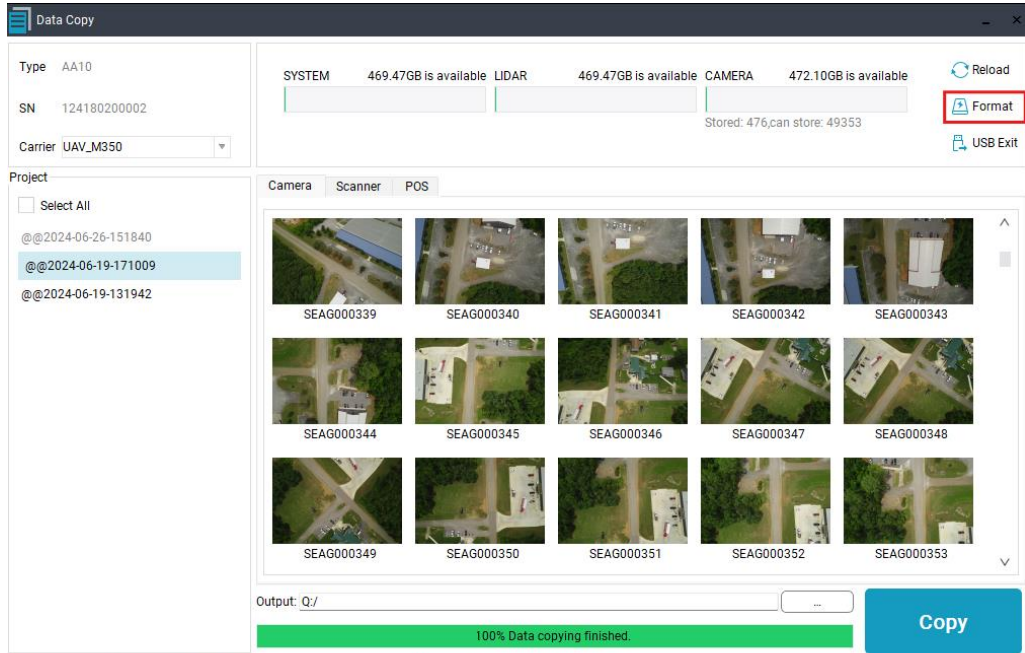

Picture number: 148 Collect time(min): 10.9 Missing picture number: 0 Missing POS number: 0

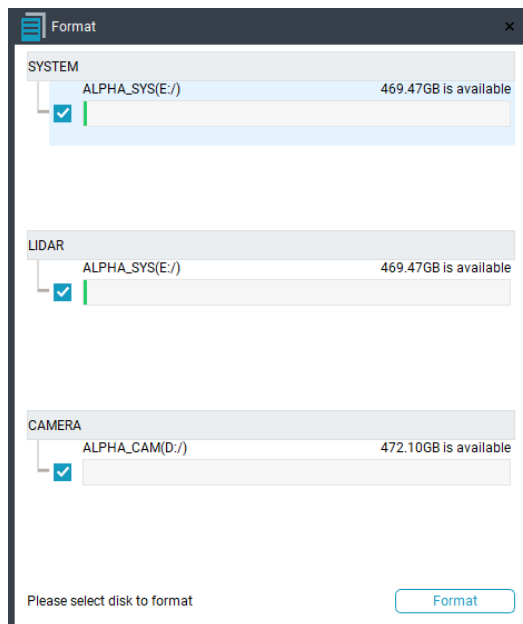

Note: If either of the disks’ memory is less than 10% or cannot meet storage requirements, the user will need to clear disk memory in advance.

Note: User can only format disk via data copy tool, otherwise, the default folders inside disk will be deleted, which will cause error.

7.3 USB Exit

After data copy finished, click “USB Exit” to eject disks first, then disconnect type-C cable between TV540 and PC.

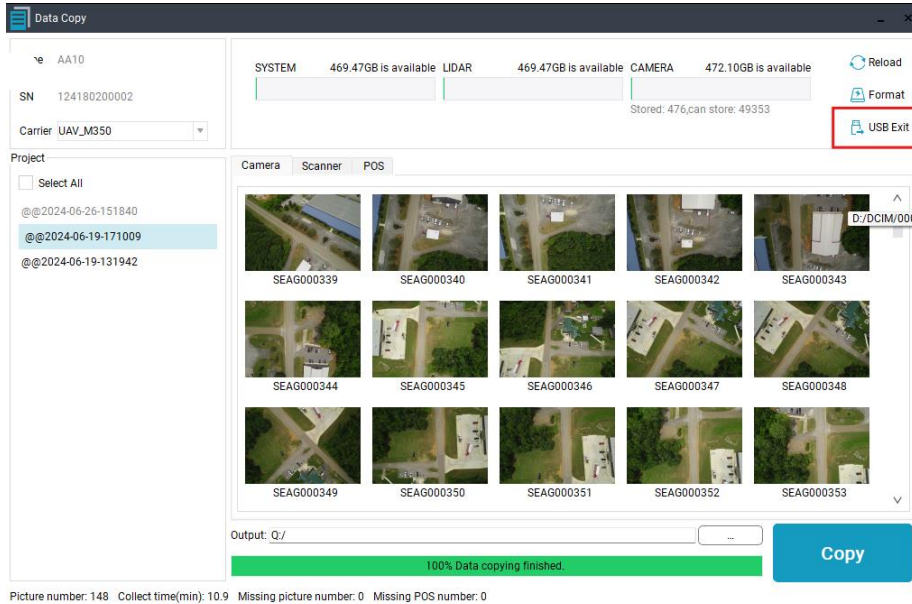

7.4 Data structure

The Data copy tool will create a project folder with defined structure automatically after data copy. Details can be seen in the figure below:

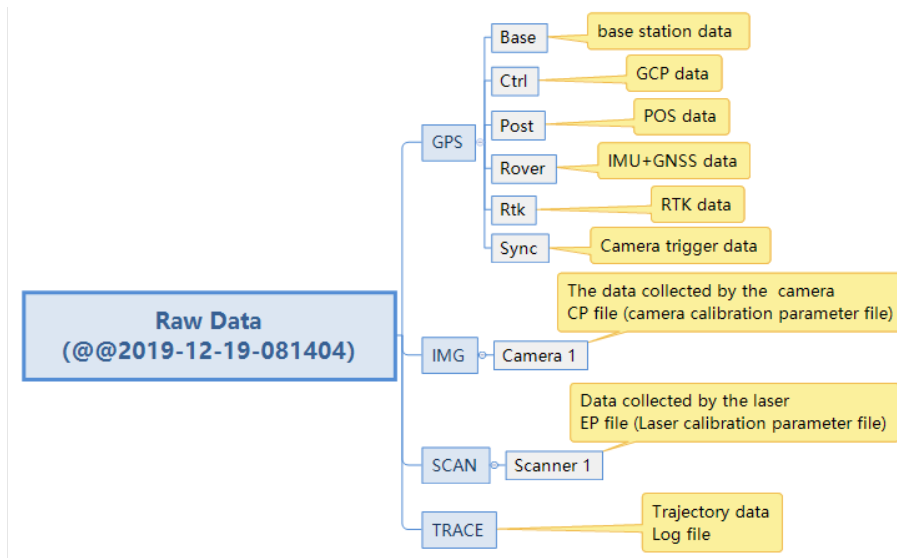

The data project folder will be named based on capture date & GPS time by default, for example “@@2021-07-30-030325”. There are four folders: GPS, IMG, SCAN and TRACE.

GPS	3/7/2022 4:00 PM	File folder
IMG	3/7/2022 4:00 PM	File folder
SCAN	3/7/2022 4:01 PM	File folder
TRACE	1/28/2022 12:09 AM	File folder

7.4.1 GPS

The GPS folder stores GNSS, IMU and processed POS data. It contains six sub-folders:

Base	2023/6/12 13:39
Ctrl	2023/5/9 8:48
Post	2023/8/15 15:35
Rover	2023/6/1 17:37
Rtk	2023/5/9 8:48
Sync	2023/5/9 8:48

- The base folder stores static data from the base station. It is empty by default.
- Ctrl folder stores GCP files. It is empty by default. User can choose to save GCP files here for data management purposes.
- Post folder stores trajectory file (.PosT format). It is empty by default.
- Rover folder stores LiDAR GNSS & IMU data. Those files will be stored automatically after the data copy is finished.
- RTK & Sync are reserved folders. They are empty by default.

7.4.2 IMG

IMG folder stores captured picture data with .CP calibration file under “Camera1” folder. The raw pictures are not geo-tagged. After picture processing is finished in LP360 software, it will store renamed geo-tagged images.

7.4.3 SCAN

SCAN folder stores captured laser raw data files with .EP calibration file under the “Scanner1” folder. The raw laser data is .ltp format.

7.4.4 TRACE

TRACE folder is a reserved folder. It is empty by default.

8 TV540 Authorization Guide

If the device license is about to expire, please contact the GeoCue Support team for registration extension or a permanent license. The support team will provide a "lic_code.bin" file. The user will need save it under ALPHA_SYS disk, then power on TV540 and it will finish registration automatically.

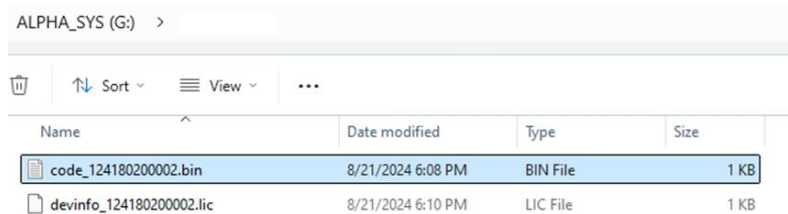

User can open the "lice_info" file to check the updated expired time.

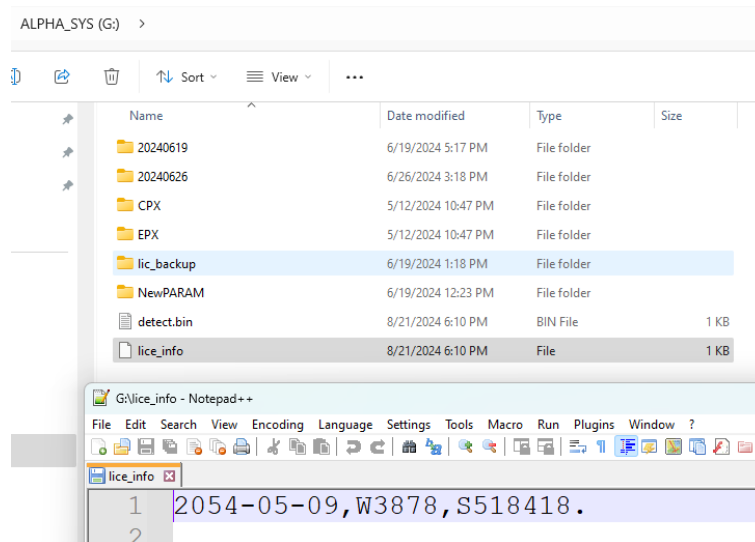

Users can also check the authorization status through the webpage.

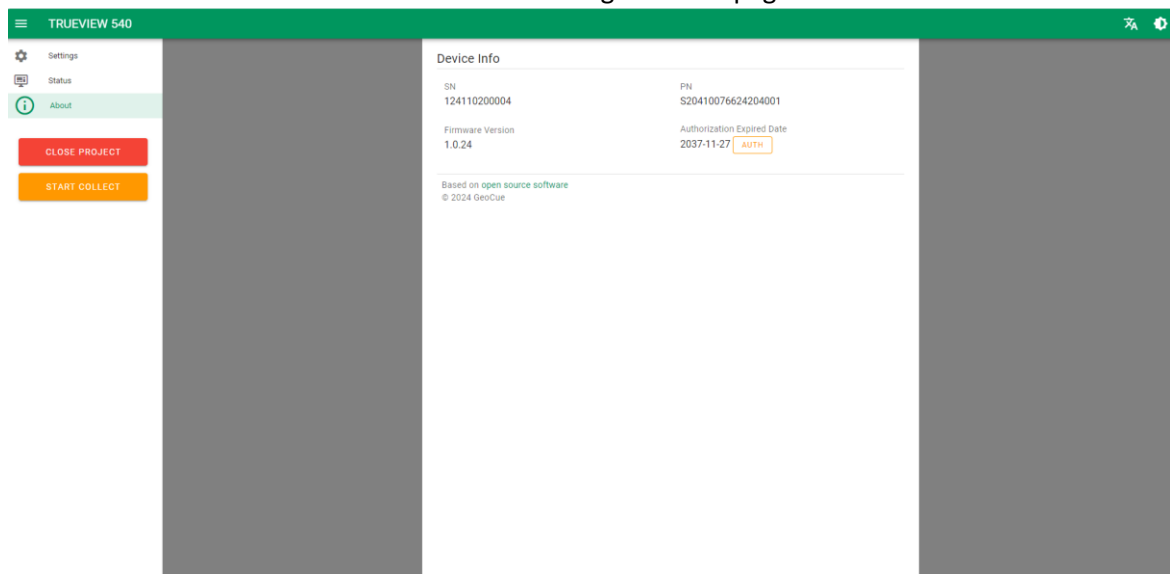

9 Additional Information

9.1 Important Notes

The LiDAR measurement system is complex and precise survey equipment. In daily carrying, using, and storing, please operate equipment correctly and maintain properly. There are some important notes listed below:

- Do not disassemble equipment. If equipment has an issue, please contact the GEOCUE support team.
- Please use the provided default accessories. The use of non-original accessories is not eligible for a warranty.
- Avoid any strong impact or vibration.
- If it is needed to continue using the instrument for a long period of time or under special conditions, such as high humidity environment, please consult with the GEOCUE support team in advance. Generally, the damage that occurred under inclement environmental conditions is not covered by the product warranty.

9.2 Product Transportation

- Please use the GEOCUE TV540 product equipped special container for transport. During transportation, make sure the container is fixed in a stable location.
- During transportation, please notify shipping personnel that this is precise system container and it needs to be handled gently. Also, attach fragile labels on the container.
- If the equipment is sent by express service, the container needs an outer box with foam inside also for safety.
- When transporting or moving batteries, take proper measures to prevent materials from falling or damaging.

9.3 Usage Tips

- The equipment should be handled gently during use to avoid soiling and scratching its surface. Please do not sit on the container.
- After the external test or operation, the surface of equipment should be cleaned regularly by using the provided cleaning equipment (at least every 3-5 days), check whether the structural screws and plugs are loose, and whether the peripheral cables are loose.
- If the unit is in long term storage, it needs to be taken out regularly (once a month) for power-on test to check whether the function is normal.
- The limitation of the environment temperature is between -20 °C to +50 °C.
- If the equipment is disassembled or loosened, it should be re-calibrated.
- When it is difficult to rotate any of the rotating parts of the equipment, please do not forcibly rotate.

- After the equipment is damaged, please do not continue using. Do not disassemble equipment in the field.
- If faced with rain or snow in the field, please move the equipment into the container quickly.

9.4 Storage Tips



- The room where the equipment is stored should be clean, dry, and well a ventilated area.
- It should be placed flat or upright. It should not be stored in a “leaned” position.

10 Frequently Asked Questions

- Equipment cannot power on or power off normally: Check whether the drone platform power supply and connection port are normal. If the unit still cannot power on or off, please contact the GEOCUE Support team for repair.
- Unit is unable to get a GNSS fix or takes a long time to get a fix: Check whether the GPS cable connection is stable.
- When connecting to the device using a mobile device's Wi-Fi function: If the user cannot access the webpage, user may need to disable mobile data on device to connect properly.
- If the images appear dark, check the camera's shutter settings to ensure they are appropriate.

11 Appendix

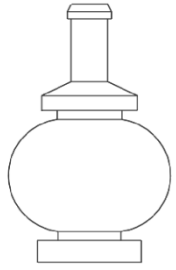
11.1 Replace DJI M300/M350 Shock Absorbing dampeners

Pictures	Name	Pcs
	Shock-absorbing dampener module	6
	M4 allen wrench	1

Note: Since the maximum load weight of the original shock-absorbing dampener of the DJI M300/M350 is less than 1Kg, it is necessary to replace the original shock-absorbing dampener.

- Take out the shock-absorbing dampeners from the transport container (slot 4).

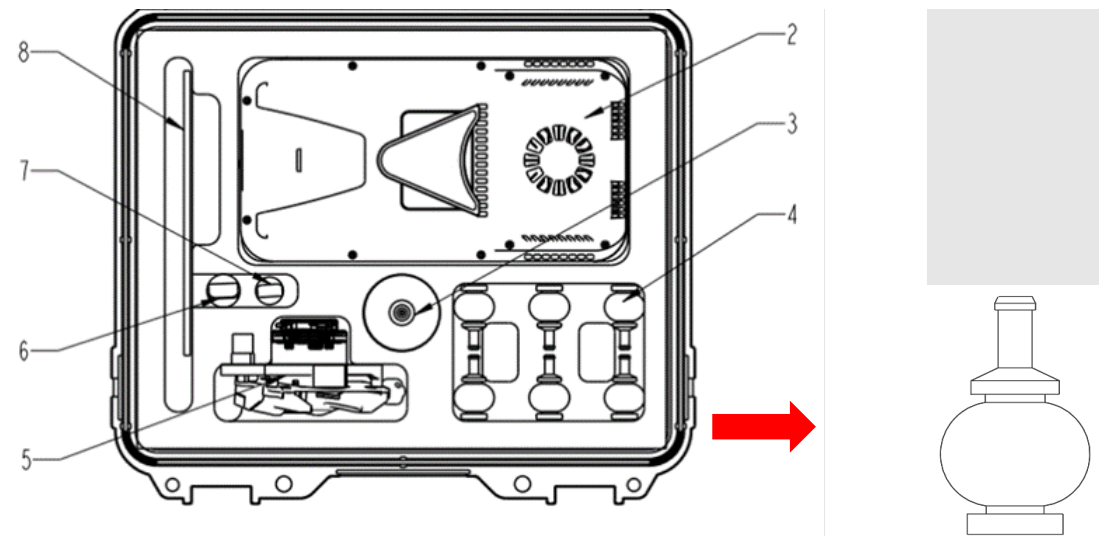

As shown in the following figure, remove the 4 original shock-absorbing dampeners from M300/M350 using the provided M4 allen wrench (it is recommended to replace all the original shock-absorbing dampeners one by one). Push the shock-absorbing dampeners from the groove edge towards the center. Repeat this process a few times until it comes off. Avoid pulling or yanking with force, as it may cause damage to the dampener.

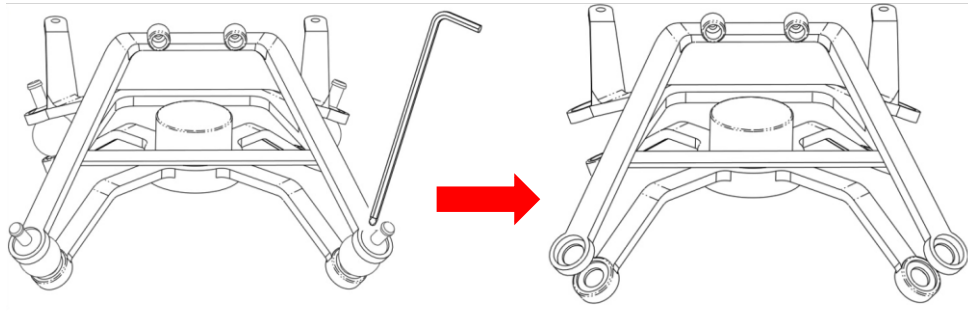

When removing the shock-absorbing dampener, use the round end "1" to remove it. Do not use the right-angle end "2" to remove it, as it may damage the shock-absorbing dampener.

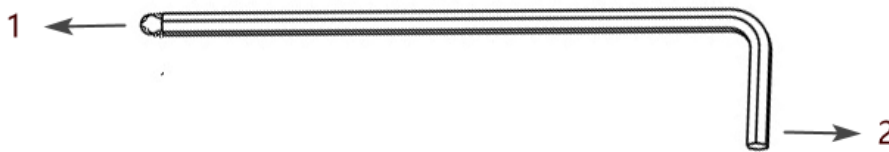

Replace all the original shock-absorbing dampeners one by one. When installing the new shock-absorbing dampener, insert the bottom rubber ring down first, then insert the top rubber column from the top bracket and pull the rubber column up.

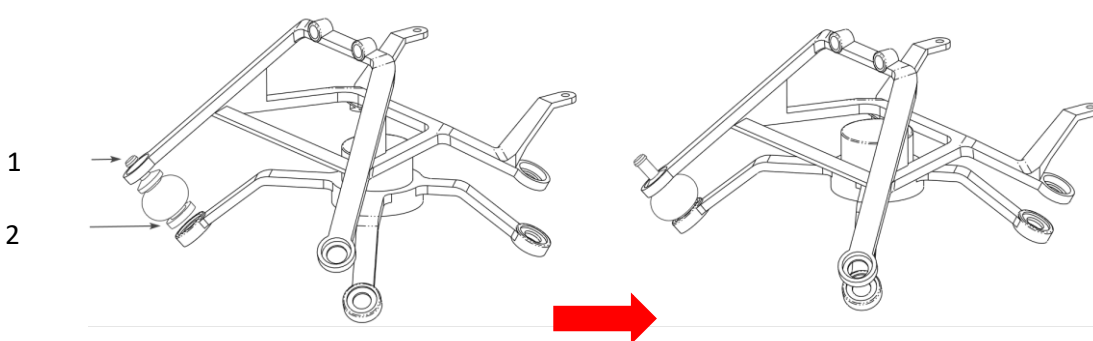

1- Top rubber column; 2- Bottom rubber ring

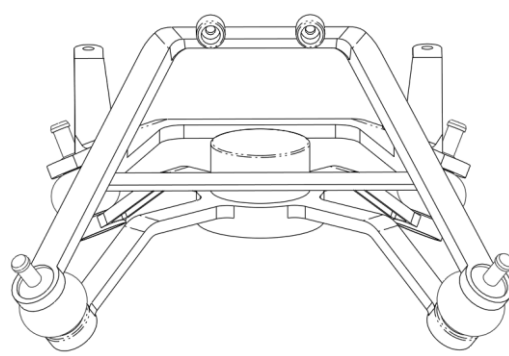

It is recommended to install a new shock-absorbing dampener every time the user removes an original dampener to prevent the load plate from falling off or becoming misaligned.

11.2 DJI M300/M350 Installation Steps

- Push the “Alphaport” slider of scanner into the quick-release clamp of the bottom of the airborne mounting platform in the direction of the arrow until a “click” sound is heard.

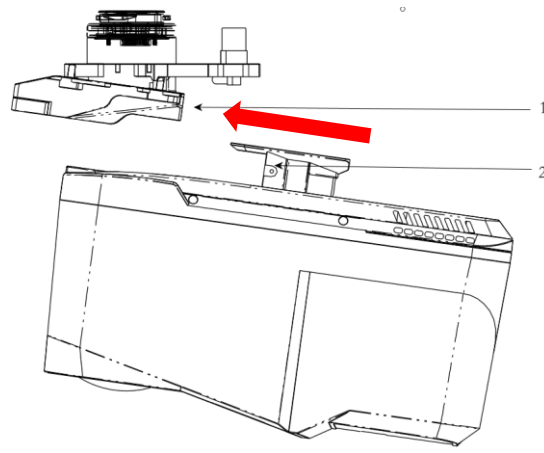

1- quick-release clamp; 2- Alphaport

- Tighten the side screw bolt to make it stable to finish the installation.

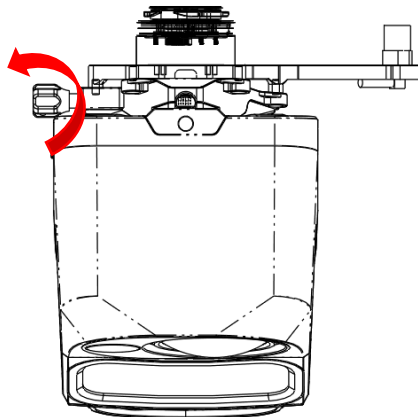

- Align the white dot on the device Skyport interface with the red dot on the M300 interface and insert it in the installation location. Rotate the device SkyPort interface to the locked position (red dots align red dots) to be fixed.

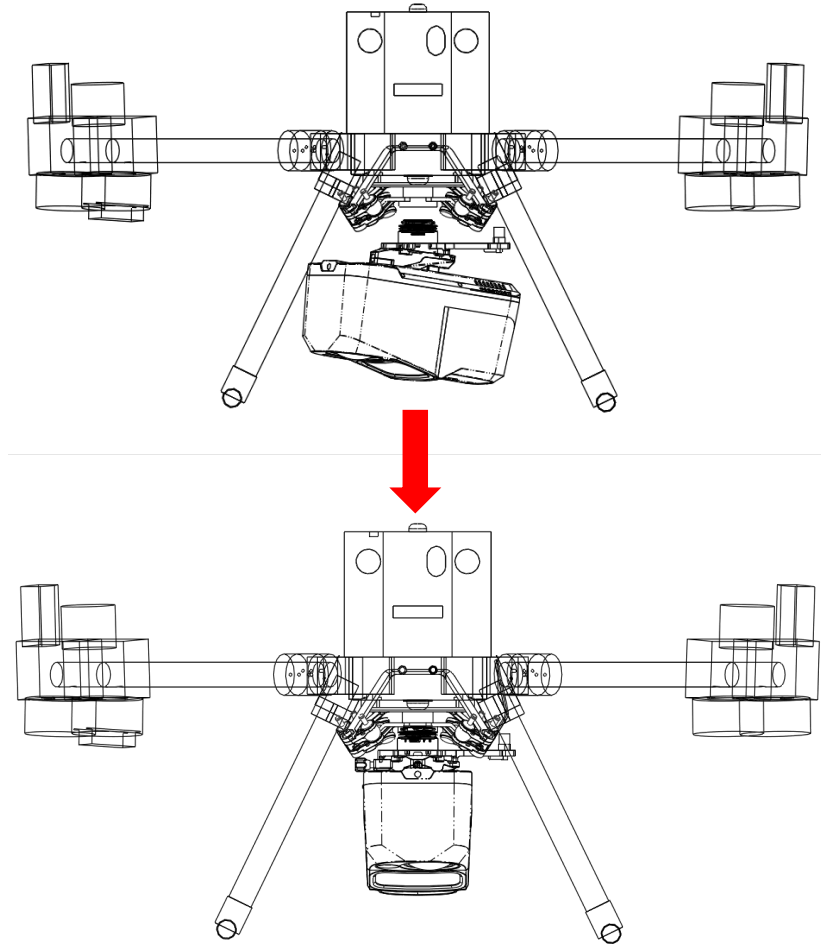

- Insert the rod antenna into the antenna mount and tighten it.

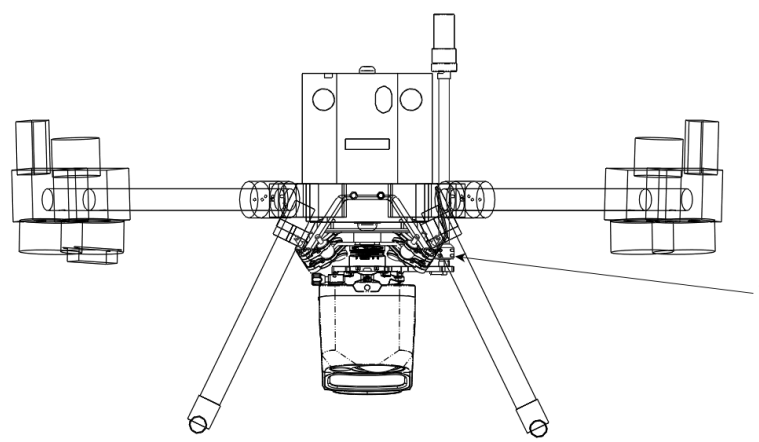

11.3 Installing TV540 On Other Platforms

If install TV540 on a third-party aircraft, it is necessary to measure the Lever Arm Offset value from Sensor Measurement Origin to Antenna Phase Center.

11.3.1 How to measure Lever Arm Offset

Measure the Lever Arm Offset value from Sensor Measurement Origin to Antenna Phase Center. The Sensor Measurement Origin is where the measurement should originate. Please refer to the actual antenna phase center as well:

- “M” is Sensor Measurement Origin on TV540 (LED indicator light).
- X is right, Y is forward, Z is up direction. If the direction is opposite, then value is negative.

For example: If using the default antenna (AV14), then $T_X = -0.08811m$, $T_Y = -0.15469m$, $T_Z = 0.29336m$.

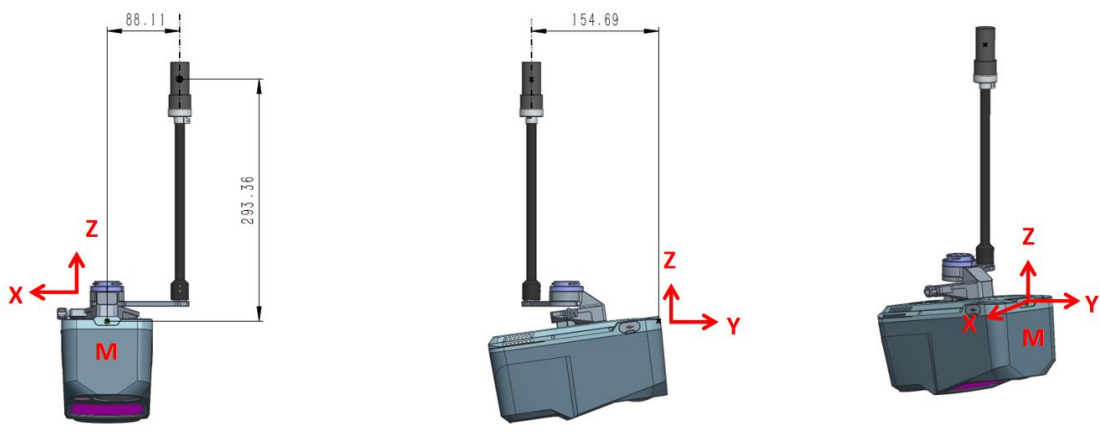

11.3.2 How to generate a new TV540 profile in LP360

- Click “Tools->Data Copy”

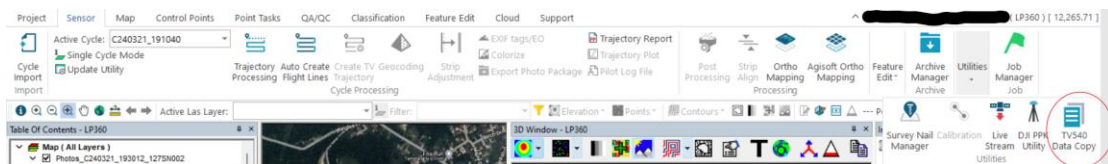

- Select User Defined when copying data:

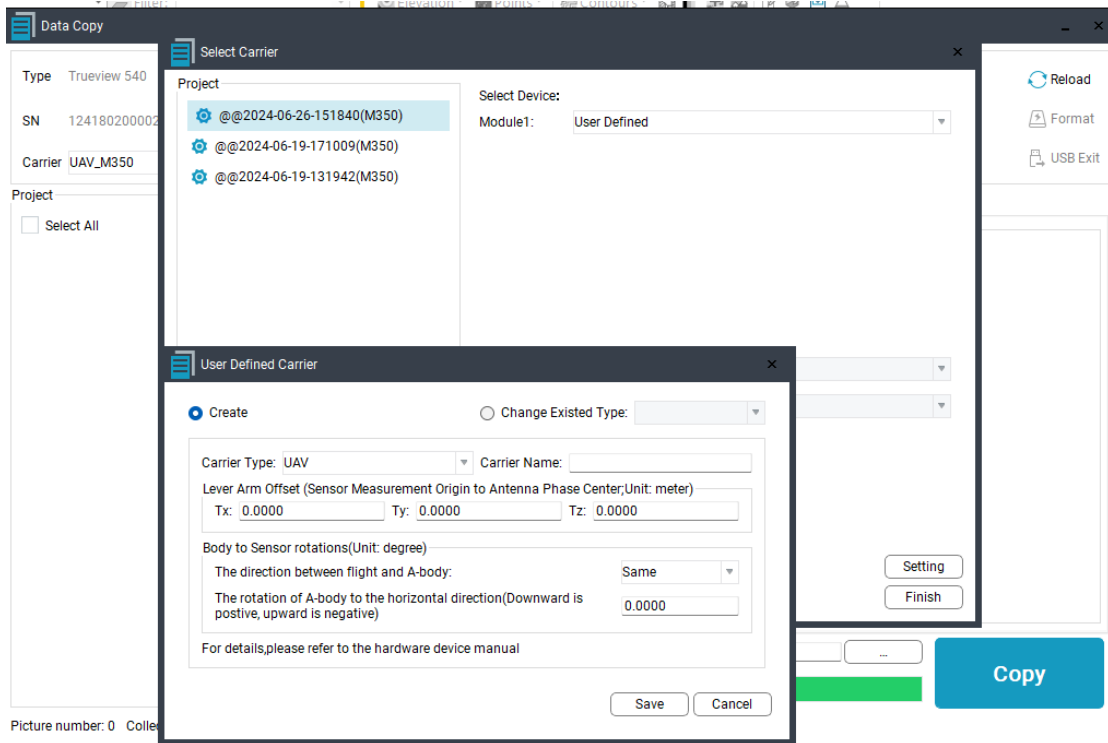

- Set parameters as shown below.

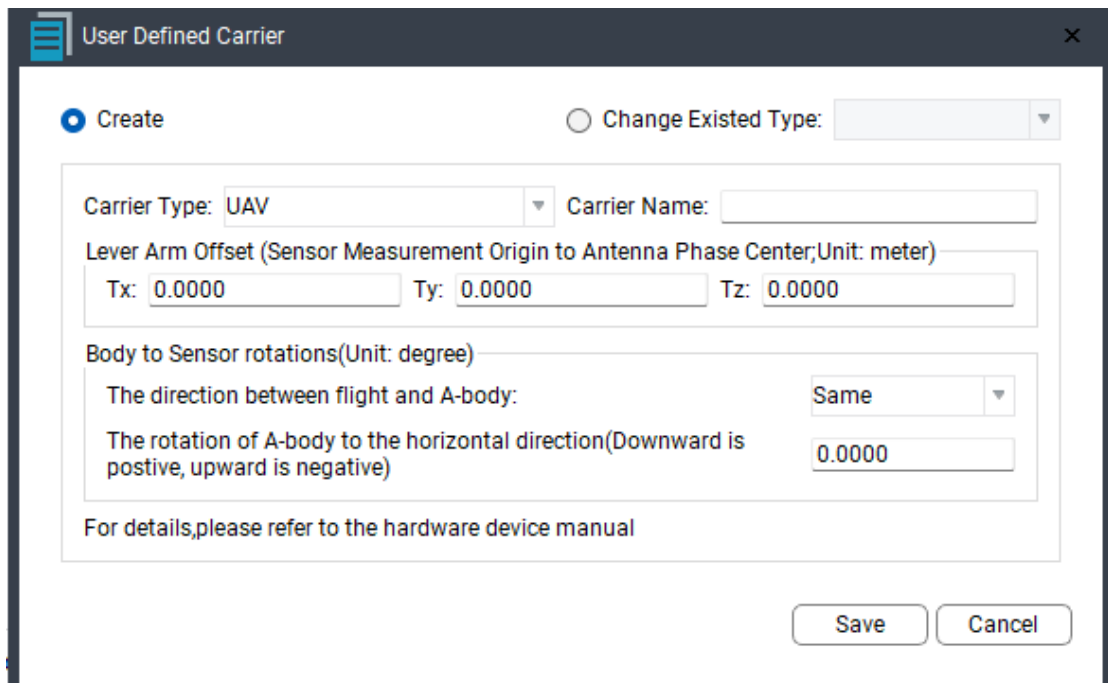

- Carrier Type: Select the original payload.
- Carrier Name: Rename the new payload type.
- Lever Arm Offset (Sensor Measurement Origin to Antenna Phase Center;Unit: meter): Enter the values from original point M to antenna phase center.

- Installation Direction (Unit: degree): Flight direction to A-port direction (Same/Opposite): If the flight direction is the same direction as the Y-axis, select same.

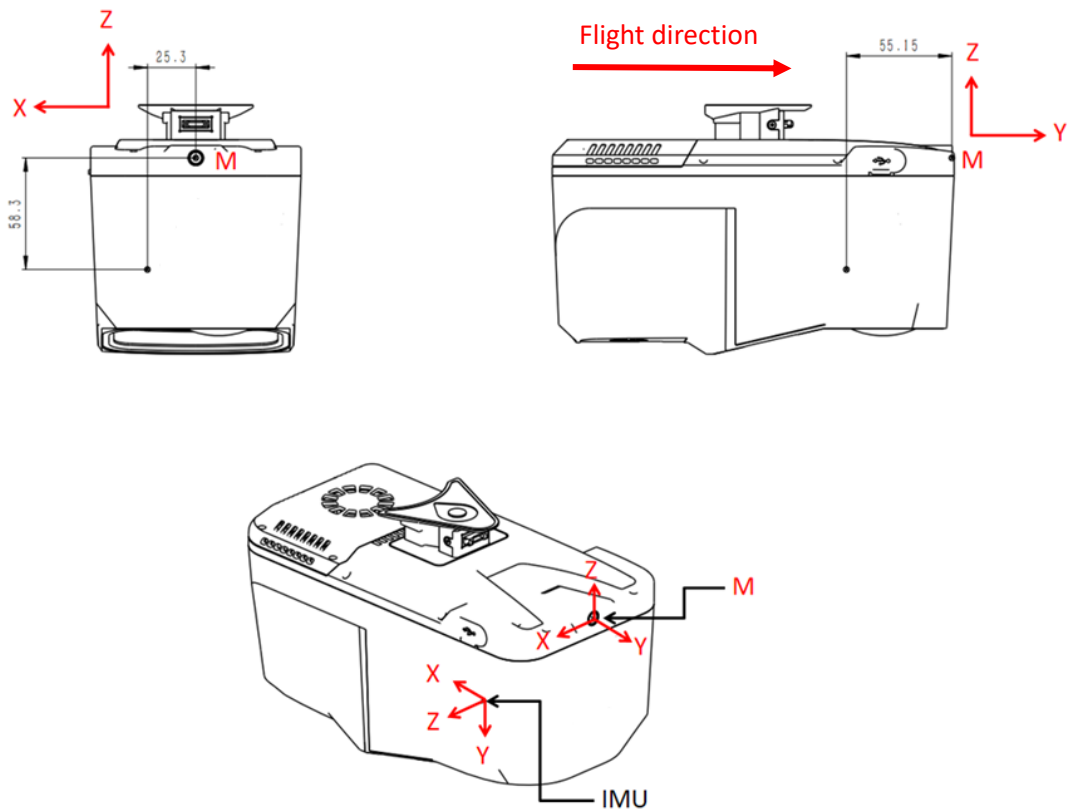

- A-port to the horizontal direction rotation (Down is positive, up is negative). If the device has no angle, value is 0, as follows:

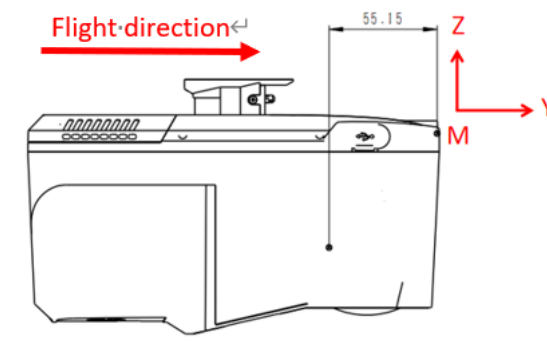

- A-port to the horizontal direction rotation (Down is positive, up is negative). If the device has angle, as follows, value is -8:

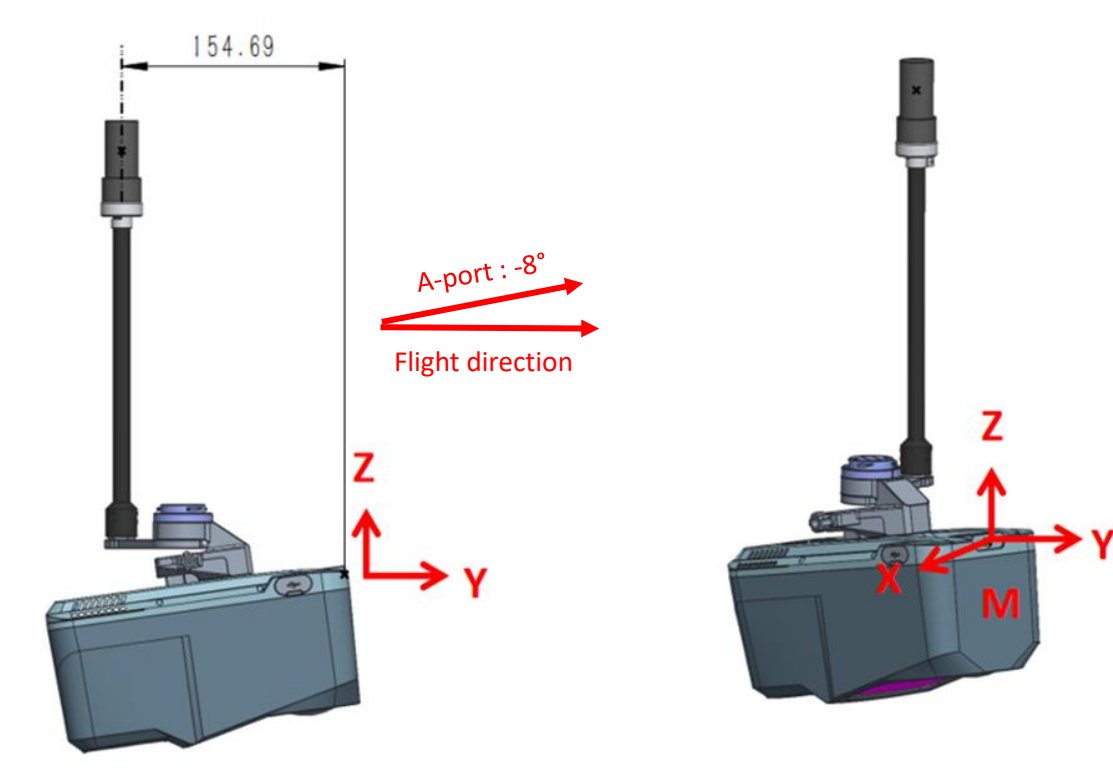

Support

Our searchable support knowledge base contains information on workflows, tips, hints, and probable resolutions to error messages or commonly encountered situations.

<https://support.geocue.com/>

Normal support business hours are **Monday - Friday, 8 AM — 5 PM** USA Central Time.

Our GEOCUE Support website contains general workflow information, in addition to specific issue and error messages that you may encounter. Click on the link and search for information contained in the knowledge base.

If a support request is sent during business hours a representative will typically get back to you within 4 hours. If received after hours, a response will be sent the following day. To speed response time please include the following information in your request:

- Contact information - please include e-mail address and phone number
- Company name
- Product name and version number
- True View Model and Serial Number

If your request includes problems pertaining to a specific error message, please include a screenshot of the error message.

For hardware and software support contact: support@geocue.com