

TrueView GO NEO

User Manual



2026-6-1 v1.0.0

SLAM Solution

Table of Contents

1 Reading Tips	4
1.1 Symbols	4
1.2 Service and Support	4
1.3 Safety Guidelines	4
1.3.1 Laser Safety Class.....	4
1.3.2 Device Drop	5
1.3.3 Power Supply.....	5
1.3.4 Transportation and Vibration	5
1.3.5 Battery Safety	5
1.3.6 Chemistry	5
1.3.7 Surface High Temperature	5
1.3.8 Use of Equipment.....	6
2 Introduction.....	7
2.1 Check List.....	7
2.2 Equipment Specifications, Dimensions and Interface.....	9
2.3 Product Parameters.....	10
3 Product Usage	12
3.1 Work.....	12
3.1.1 Battery Charge.....	12
3.1.2 Equipment Installation	13
3.1.3 Mobile Phone Bracket Installation	13
3.1.4 Software	14
3.2 Data Acquisition.....	15
3.2.1 Equipment Start-up	15
3.2.2 Device Connection.....	15
3.2.3 Device Diagnostics	17
3.2.4 Project Management.....	18
3.2.5 Log Upload.....	18
3.2.6 Infrastructure.....	19
3.2.7 RTK Settings.....	19

3.2.8 Other Settings.....	20
3.2.9 Start Collecting	21
3.2.10 One-click Collection	24
4 Collection Guide	26
4.1 Route Planning	26
4.2 Loop Requirement.....	26
4.3 Precautions for Data Acquisition	26
5 Data Processing in LP360 Land	28
6 Frequently Asked Problems and Solutions	37
6.1 NEO Host	46
6.2 TrueView GO APP	46
7 Daily Use and Precautions	47
7.1 Use.....	47
7.2 Daily Service Specification	47
7.3 Equipment Transportation	48
7.4 Equipment Storage	48

1 Reading Tips

1.1 Symbols

Forbid 

Warning 

Important note 

Operate & Using tips 

1.2 Service and Support

For assistance, please first consult this manual, our website, www.geocue.com, or your local GeoCue dealer. If your issue remains unresolved, you can contact our technical support team directly at support@geocue.com.

1.3 Safety Guidelines

1.3.1 Laser Safety Class

CLASS 1 LASER PRODUCT

This product complies with IEC 60825-1:2014, EN 60825-1:2014+A11:2021, EN 50689:2021 and complies with FDA performance standards for laser products except for conformance with IEC 60825-1 Ed.3., as described in Laser Notice No.56, dated May 8, 2019.

1.3.2 Device Drop

This product contains precision electronic components.

- Dropping, crushing, puncturing, or improper handling may cause permanent damage.
- If the device is dropped, stop using it immediately and contact GeoCue after-sales support for assistance.

1.3.3 Power Supply

- Ensure the power interface is dry and free of debris before powering on.
- Only use power cables and adapters provided or approved by GeoCue.
- Do not use damaged power cables or adapters that do not meet the specified power requirements.

1.3.4 Transportation and Vibration

- Avoid strong vibration and mechanical shock to prevent damage to the device.
- Mechanical shock or vibration exceeding the allowable range may damage the product.
- GeoCue is not responsible for equipment damage caused by improper logistics handling during transportation.

For detailed shock and vibration specifications, please contact GeoCue technical support.

1.3.5 Battery Safety

- Do not immerse the battery in water. Store it in a cool, dry place when not in use.
- Keep the battery away from heat sources during both use and storage.
- Avoid short circuits by keeping battery terminals away from metal objects.
- Do not tap, drop, or step on the battery.
- Do not weld or puncture the battery with sharp objects.
- If the battery is not used for an extended period, maintain its charge level between 30% and 50%. Fully charge and discharge the battery at least once every three months.

After around 500 charge cycles, battery capacity may decrease to approximately 80% of the original capacity.

1.3.6 Chemistry

Do not expose the product to corrosive or highly reactive chemicals (liquids or gases), including but not limited to strong acids, strong bases, esters, or ethers. Such exposure may cause damage, including the loss of waterproof protection.

1.3.7 Surface High Temperature

During operation and for a period after use, the device surface may become hot.

- Avoid direct skin contact with the product shell to prevent burns.
- Keep flammable materials away from the device to reduce the risk of fire.

1.3.8 Use of Equipment

Use and maintain the device in accordance with this user manual. Damage, reduced service life, or malfunction resulting from improper use, improper maintenance, or unauthorized disassembly is not covered by warranty. All related repair and maintenance services will be charged according to standard service fees.







2 Introduction

The TrueView GO NEO is a handheld 3D SLAM and LiDAR scanning product launched by GeoCue, delivering uncompromising performance. It adopts deep integration of high-precision inertial navigation and SLAM technology, incorporating a high-frequency ultra-wide-angle LiDAR for full-grid online scanning details and a 48MP high-definition camera for pixel-level reproduction of scanned scenes. The device features fully open hardware interfaces and SDKs, and together with LP360 Land, builds a cloud-integrated data processing workflow. Focused on full-scenario adaptability with a minimalist operation process, the TrueView GO NEO is primarily used in fields such as architectural surveying, interior design, decoration and renovation, and underground space measurement. It provides a cost-effective 3D data acquisition entry-level solution that reduces costs and increases efficiency.

2.1 Check List

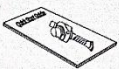
 **Note:** Please refer to the actual delivery list.

TrueView GO NEO Surveying System configuration list is shown below:

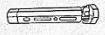
 <p>Main Unit</p> <p>x1</p>	 <p>Smart Handle</p> <p>x1</p>	 <p>Phone Holder</p> <p>x1</p>	 <p>Quick Start Guide</p> <p>x1</p>
 <p>Laser Head Lens Cleaning Cloth</p> <p>x1</p>	 <p>National Standard Charger</p> <p>x1</p>	 <p>Data Cable</p> <p>x1</p>	
<p>● Optional system components</p>			
 <p>1/4 to 5/8 Nut Converter</p> <p>x1</p>	 <p>Tripod</p> <p>x1</p>		

N	Description	Pcs	Type
1	TrueView GO NEO unit	1	Standard
2	Smart Handle	1	Standard
3	Phone Holder	1	Standard
5	Laser Head Lens Cleaning Cloth	1	Standard
6	Power Adapter	1	Standard
7	Data Cable	1	Standard
8	Quick Start Guide	1	Standard
9	1/4 to 5/8 nut converter	1	Optional
10	Tripod	1	Optional

2.2 Equipment Specifications, Dimensions and Interface

The weight of the equipment is about 1.2 kg.

The length, width and height (118 × 90 × 304 mm) are as follows:

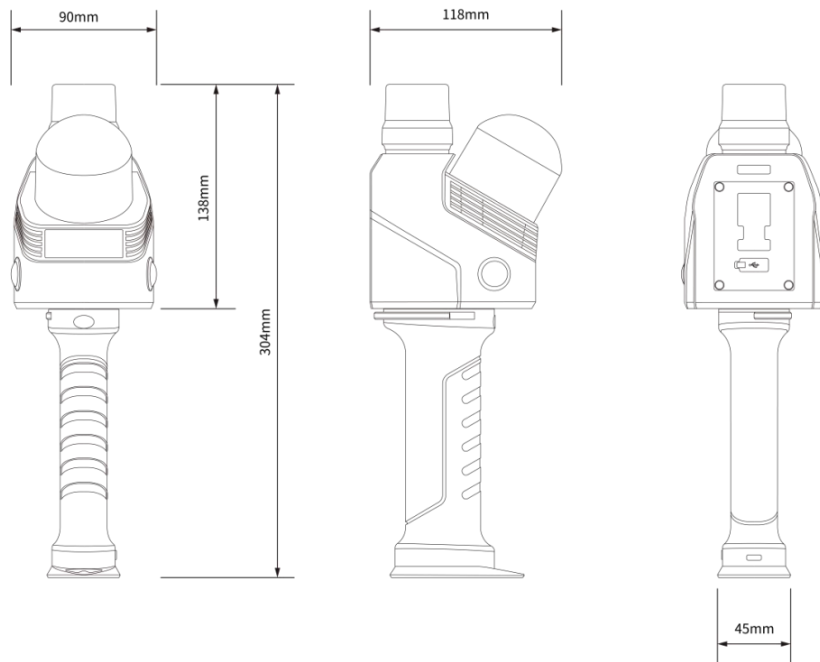

Interfaces and Indicators

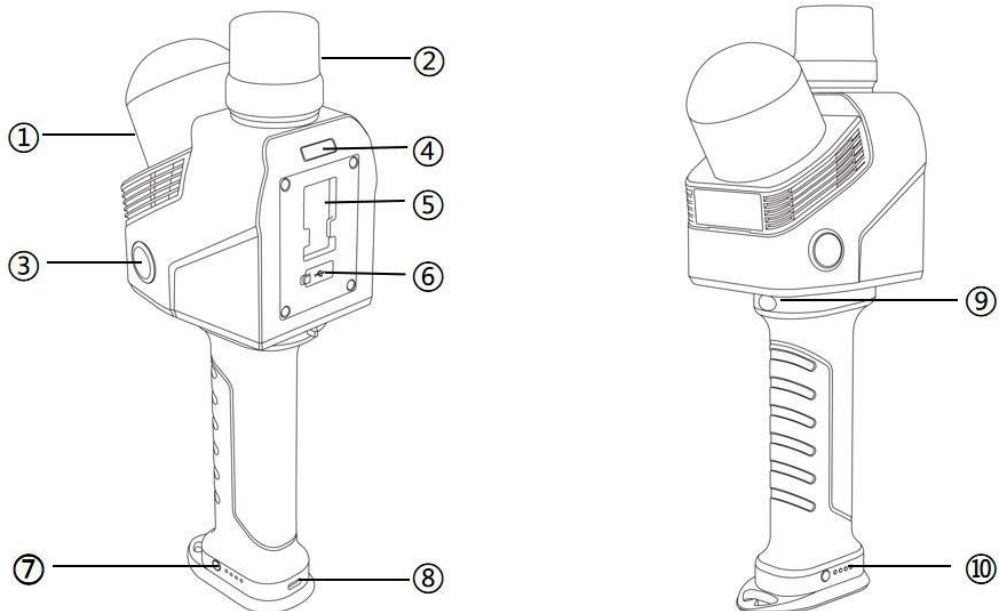

- | | |
|-----------------------------|-------------------------------|
| ① LiDAR | ⑥ Data transmission interface |
| ② RTK antenna | ⑦ Handle battery button |
| ③ Camera | ⑧ Charging port |
| ④ Unit status indicator | ⑨ Function button |
| ⑤ Handset bracket interface | ⑩ Handle battery indicator |

2.3 Product Parameters

System parameter	Absolute accuracy	Horizontal: < 3cm RMS ① Vertical: < 3cm RMS ①
	Relative accuracy	<1cm②
	Repetition accuracy	<2cm②
	Power supply	Battery Handle
	Battery capacity	47.5wh
	Single cell operating time	About 150 minutes ③
	Power consumption	16W
	Waterproof and dustproof grade	IP64④
	Storage capacity	512G
	Operating temperature	-20~50°C
	Weight	1.2kg (including handle battery)
Laser parameters	Field of view	360°*189°
	Laser safety class	Class1
	Ranging	40m (10% reflectivity)

	Point frequency	1152000 points/sec
	Number of laser channels	64
	Wavelength	905nm
	Echo	2
Position and pose system	Satellite system	GPS: L1, L2, L5 GLONASS: L1, L2, Galileo: E1, E5a, E5b BeiDou: B1,B2,B3 QZSS: L1C/A, L1C, L2C, L5, L6
IMU	UPDATE	500Hz
	Gyroscope bias instability	0.5°/hr
	Gyroscope random walk	0.01°/√hr
	Accelerometer bias instability	10ug
	Accelerometer random walk	0.017m/s/√hr
Camera	Quantity	2
	Resolution	4800w
	Sensor size	1/2 in.
	Field of view	340° (H) *360° (V)

① ② Measured at the GeoCue standard test site. Deviations may occur in certain scenarios.

③ Measured at room temperature (25 °C) with the equipment at rest.

④ It offers splash-proof, waterproof, and dustproof protection. This protection performance has been tested and verified in a standard laboratory environment. According to the IEC 60529 standard, the protection level is rated IP64.

3 Product Usage

3.1 Work

3.1.1 Battery Charge

Use the standard power adapter to connect the charging cable to the handle battery.

- It takes approximately two hours to charge the battery power from 0% to 100%.
- Do not connect the charging cable to the Type-C interface of the host and turn off the phone to charge.

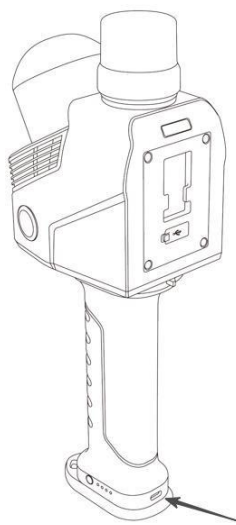

The device indicator light shows the remaining battery power of the handle, please refer to the table below for details.

indicator lamp	state	Device power
● ○ ○ ○	One-cell indicator flashing	0-10%
● ○ ○ ○	One-cell indicator lamp always on	10%-20%
● ● ○ ○	One-cell indicator flashing,one-cell indicator lamp always on	20%-30%
● ● ○ ○	Two-compartment indicator lamp always on	30%-40%
● ● ● ○	Two-compartment indicator lamp always on,one-cell indicator flashing	40%-55%
● ● ● ○	Three-compartment indicator lamp always on	55%-70%
● ● ● ●	Three-compartment indicator lamp always on,one-cell indicator flashing	70%-85%
● ● ● ●	Four-compartment indicator lamp always on	85%-100%

3.1.2 Equipment Installation

- Release the handle latch,
- Insert the battery handle into the bottom groove of the main unit.
- Ensure the battery is securely installed, then lock the handle latch.

Caution: Ensure the handle latch is locked, otherwise it may cause poor battery or device drop.

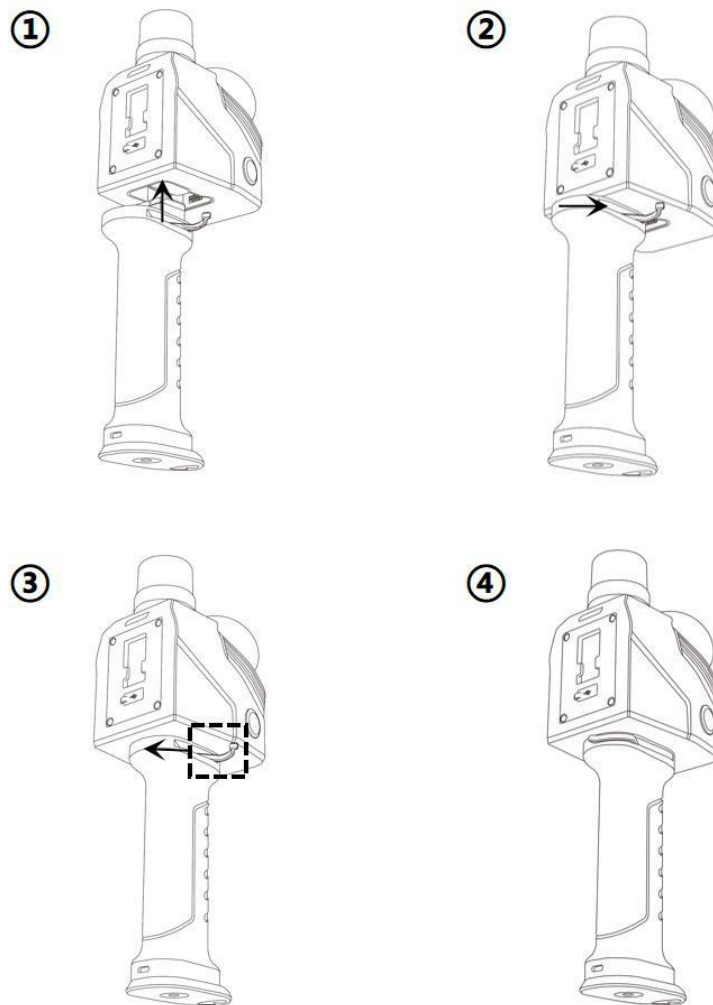

3.1.3 Mobile Phone Bracket Installation

- Align the bottom of the mobile phone mount with the mounting interface on the back of the main unit.
- Tighten the mounting knob to secure the bracket.
- After the installation is completed, the angle of the bracket can be freely adjusted.

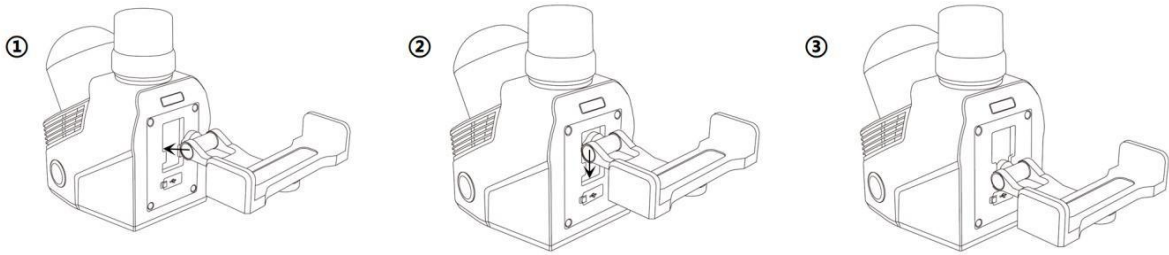

3.1.4 Software

The TrueView GO NEO data acquisition software is the TrueView GO APP, a comprehensive application control software. TrueView GO APP provides a full 3D display of routes and terrain, presenting complex work sites to users more intuitively.

To download and install the software login to your LP360 Portal. Click the Download sections and then download the TrueView GO APP. Currently, the TrueView GO App is only supported on Android systems.

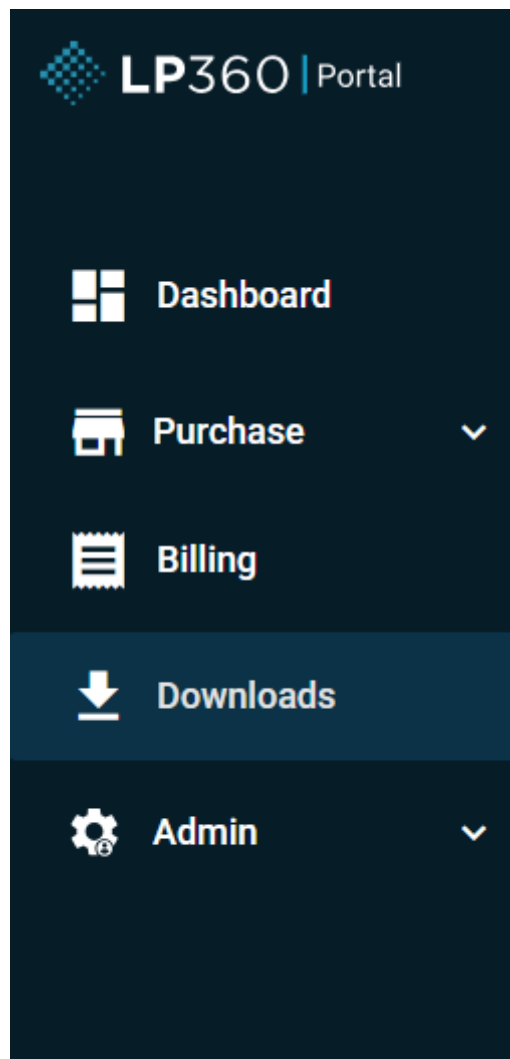

3.2 Data Acquisition

3.2.1 Equipment Start-up

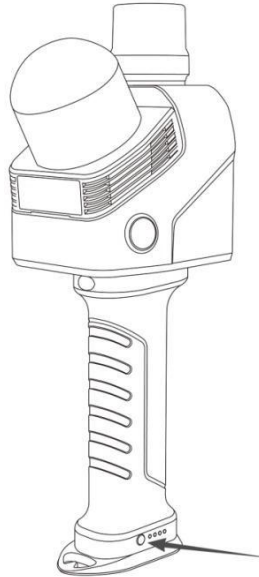

- After the handle battery is installed, short-press and long-press the buttons under the handle for 2 seconds.
- When the power indicator lights turn on in turn and the host indicator light is solid green, the device is turned on.

Main Unit Indicator Status

Indicator Light Status	Meaning
Green Light Steady On	Device Powered On
Blue Light Running Light	Device Self-Checking
Blue Light Steady On	Device Self-Check Completed, Ready
Green Light Fast Blinking	Device Initializing
Blue Light Slow Breathing	Device Collecting Data
Green Light Slow Blinking	Data Saving
Yellow Light Breathing	Abnormal During Data Collection
Red & Green Lights Alternately Blinking	Firmware Upgrading
Red Light Steady On	Device Fault

3.2.2 Device Connection

- Open the TrueView GO APP software and select SLAM job, select the device WIFI name starting with SLAM-xxxx on the device connection interface and connect, no password is required.



After connection:

- Check device battery level and remaining storage.
- Check firmware and software versions.
- Confirm device authorization status. If authorization has expired, contact GeoCue technical support.

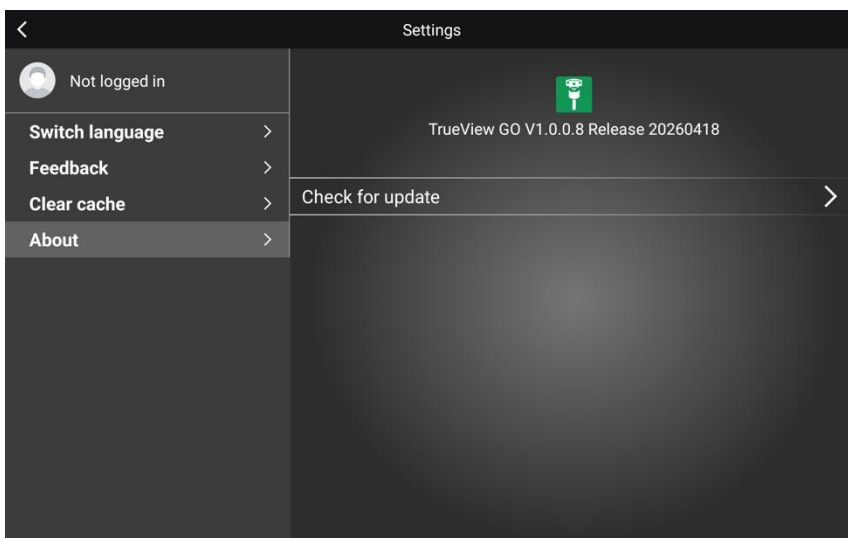
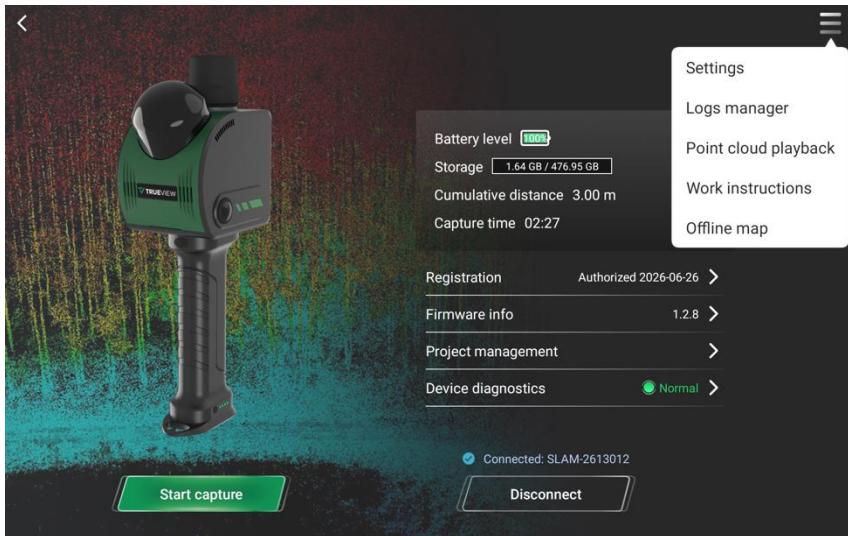

3.2.3 Device Diagnostics

- Click device diagnostics to view the status of various sensors of the current device. If there is any abnormality, restart the device and try to recover. If the restart cannot be resolved, contact the after-sales personnel of GeoCue.

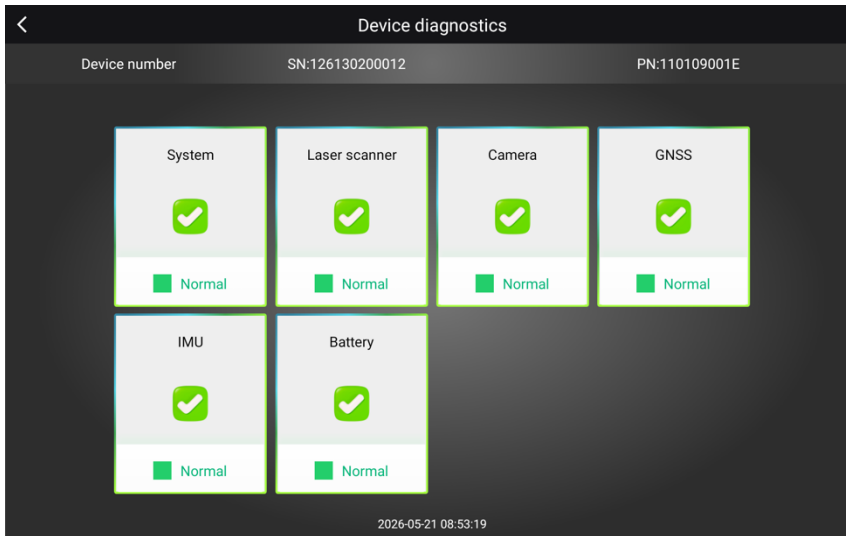

3.2.4 Project Management

- Click on the project management to view historical collected project information, including project name, real-time point cloud thumbnails, creation time, collection time, collection mileage, etc.
- Click Manage to manually delete historical projects, then the raw data in device will be synchronized delete too.

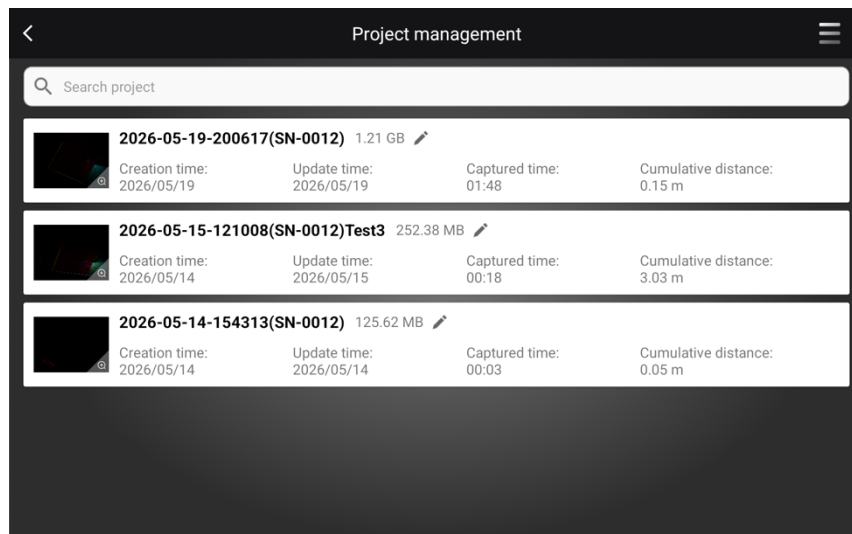

3.2.5 Log Upload

- If you encounter problems during the use of the device, you can upload the log for analysis. When the device is connected, click the  upper right corner of the software to select Log Management and click Package Log.
- Select the corresponding date and confirm. The software will automatically package the current device log.
- After clicking Upload, you can Contact GeoCue after-sales personnel to download.

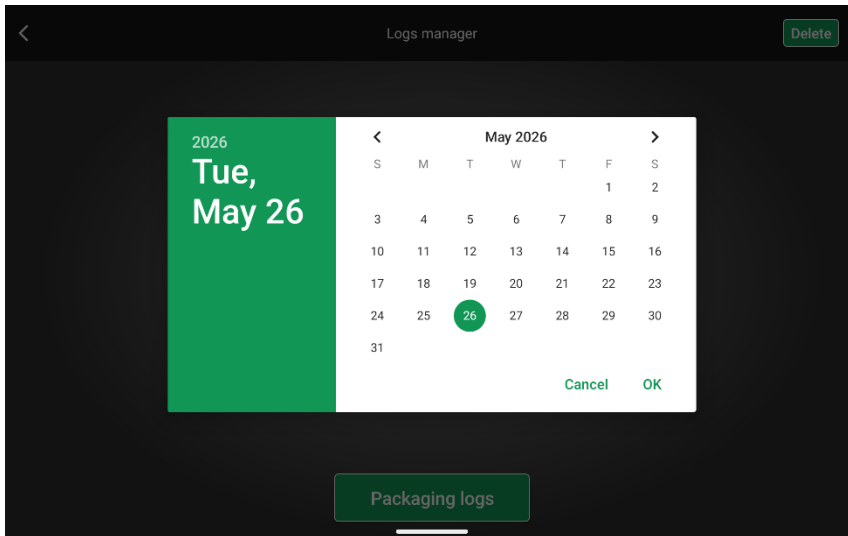

3.2.6 Infrastructure

After connecting the device, click 'Start Capture' to enter the collection interface, click the setting button in the upper right corner of the software to enter the basic setting interface.

- Turn on the 'Colored point clouds'. It will use the camera to color the point clouds in real time during the data collection process.
- Turn on the 'Use camera', and the camera will take photos when the device is collecting data, which can be used to coloring point clouds, build mesh models, etc. The camera will not work if this is disabled.
- The low battery reminder percentage can be set. When the set threshold is reached, TrueView GO APP will actively remind you that the battery is too low, please charge in time.
- Turn on the broadcast, and the software will broadcast the status information of the device in real time during the use.

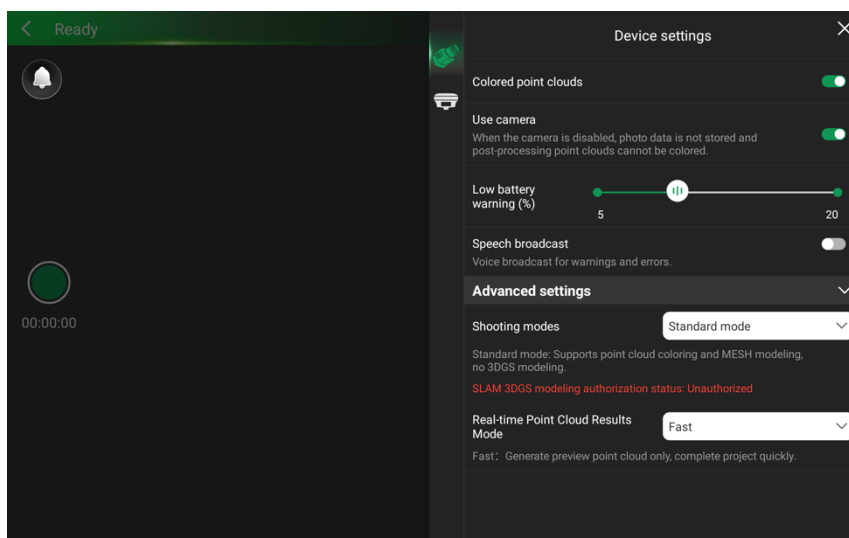

3.2.7 RTK Settings

- After connected, enter the collection interface, click the setting button in the upper

right corner, enter the RTK setting interface, open the CORS account type, enter the corresponding server address, port, username and password, obtain the source list, and click Connect.



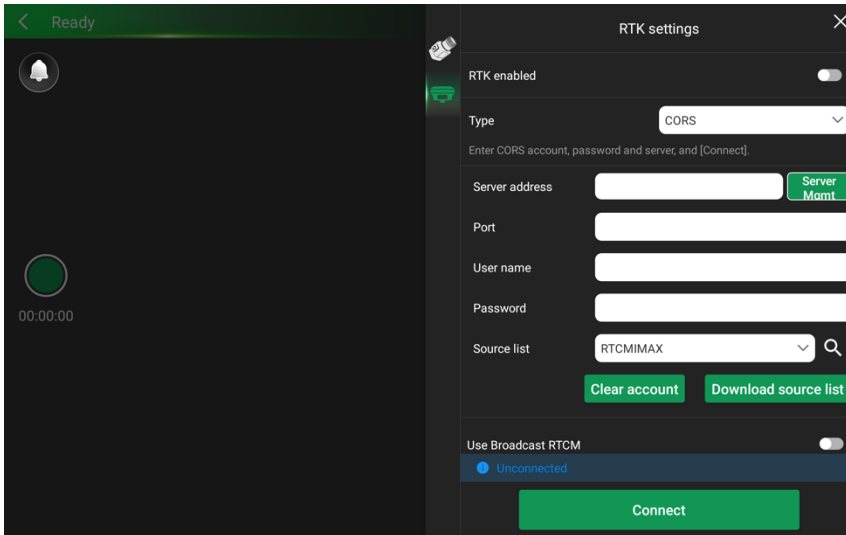



- The types of CORS accounts currently supported are: one-click fixed, GeoCue CORS, CORS, Qianxun CORS, APIS.



Note: Ensure the device is under CORS coverage and the mobile phone has internet access.

3.2.8 Other Settings

The main interface of the software can display device status information in real time. The specific information types and explanations are as follows:

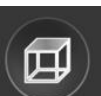
-  Displays memory used and remaining on device
-  Indicates the connection status of the phone and device
-  Indicates the satellites search status and number
-  Indicates the remaining power of the device
-  Indicates the remaining battery of the phone
-  Point clouds of different elevation ranges can be displayed with this setting
-  Point clouds can be restored to top view state with one click



Can display/hide real-time point cloud information with one click



Different point cloud renderings, currently supporting elevation rendering, intensity rendering, mixed rendering and color rendering



You can clear the real-time point cloud of the TrueView GO APP interface with one click, this operation will not delete the data collected inside the device



The current warning and error information of the device will be displayed, please deal with it according to the displayed information, if it cannot be resolved, please contact GeoCue after-sales service

3.2.9 Start Collecting

① **Create a project:** Enter the acquisition interface, click the green button on the left side of the screen to create a new project. The default project name is the collection time and the last four digits of the device SN. Manual modification of the project name is supported.

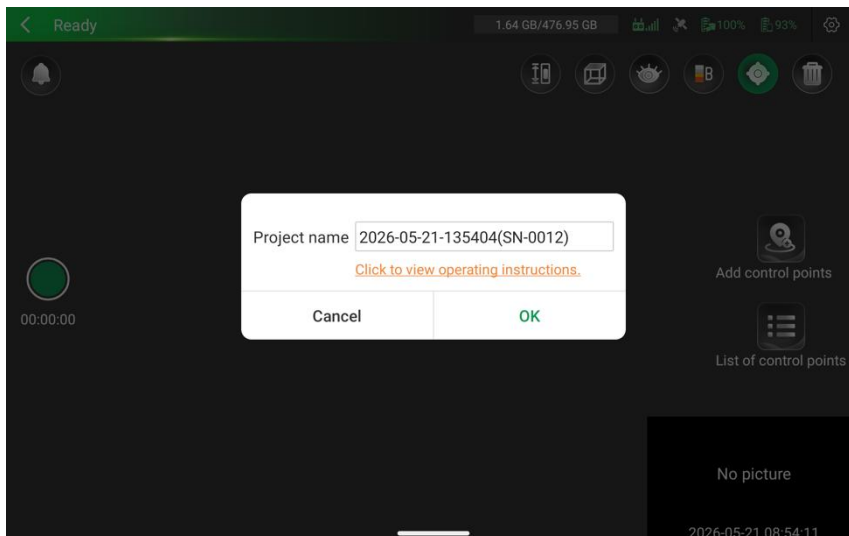

② **Equipment initialization:** After the project is created, it needs to be initialized. Refer to the following initialization precautions:

- a. Once the equipment stabilizes, the countdown disappears and initialization is complete—no need to place it on the ground.
- b. During initialization, point the device toward feature-rich objects such as buildings, irregular rocks, etc., and avoid open or featureless areas.
- c. The laser protective cover must be removed during initialization. Avoid pointing the device at moving objects or manually blocking the laser head.

- d. Try to avoid highly reflective objects such as glass or mirrors during initialization to reduce noise.

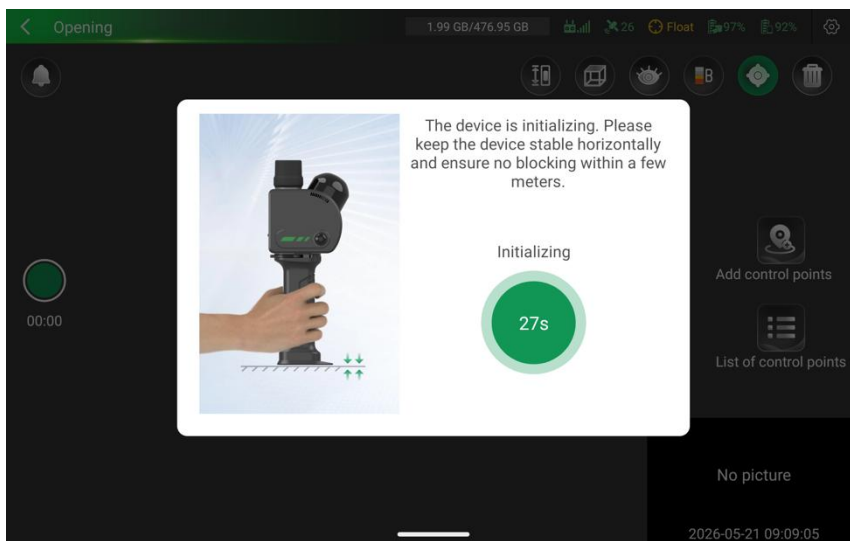

③ **Data collection:** Once initialization is complete, data collection can begin according to the pre-planned walking route. During the process, the TrueView GO APP interface displays the collection trajectory and real-time point cloud information. Use one finger to drag and rotate the point cloud, and two fingers to drag and translate it. Throughout the collection, pay close attention to the real-time point cloud display to ensure complete coverage of the target area without any missing data.

Note: Real-time point cloud display consumes mobile phone memory. If memory usage is high, the software will clear the display buffer without deleting original device data.

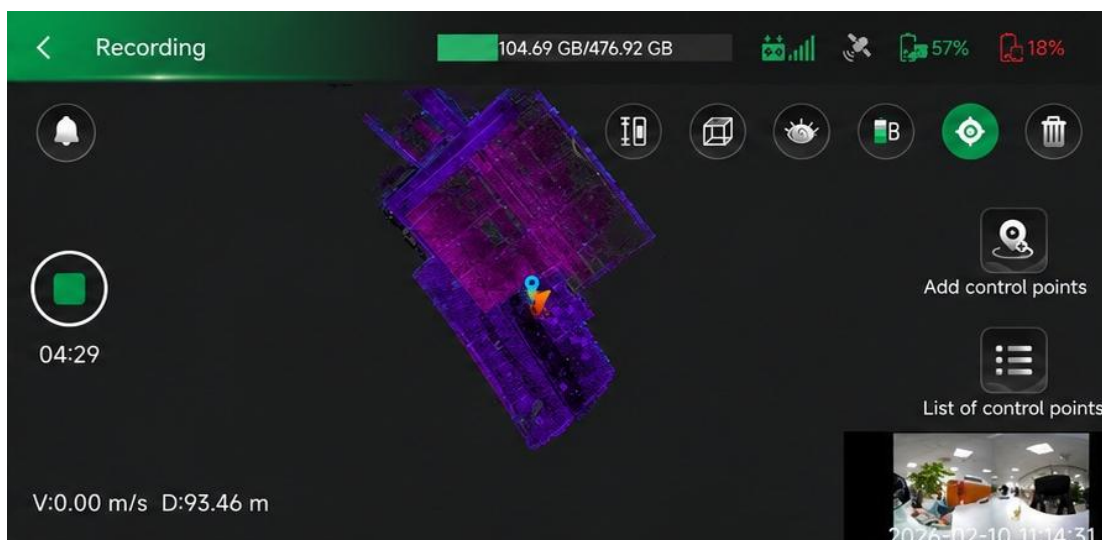

④ **GCP collection:** During data collection, click Add Control Point on the right side of the interface to collect control points. First, click Add Control Point and enter the name of the

control point. Then, align the tip of the device handle with the control point to be collected. Once stable, click Confirm to complete the control point acquisition.

Click on the Control Points List to view all control points collected in the current project and delete selected control points if needed.

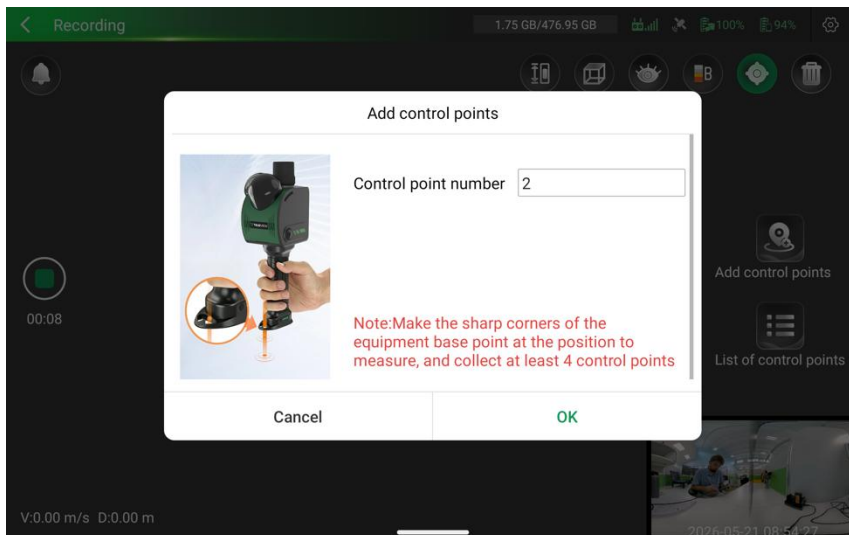

Refer to the following precautions when collecting control points:

- a. When collecting the control point, squat down and get up smoothly.
- b. Avoid people covering the front of the device when the control point is collected.
- c. For the same project, at least four control points are required to complete the coordinate conversion. It is recommended that the control points be evenly distributed in the survey area and avoid being distributed on a straight line.
- d. When collecting control points, there is no requirement for the angle of the equipment itself, and the acquisition of control points can be completed upright, horizontal and backward.
- e. After the control point is collected, wait 15s before finishing the project.
- f. Avoid collecting control points in narrow areas to prevent the laser head from being obstructed.

⑤ **End collection:** After the data scanning is completed, click the green button on the left to end the collection, and the device will automatically generate a real-time las point cloud file of the current project, store it in the original project-SLAM DATA folder, and shut down after the project is saved.

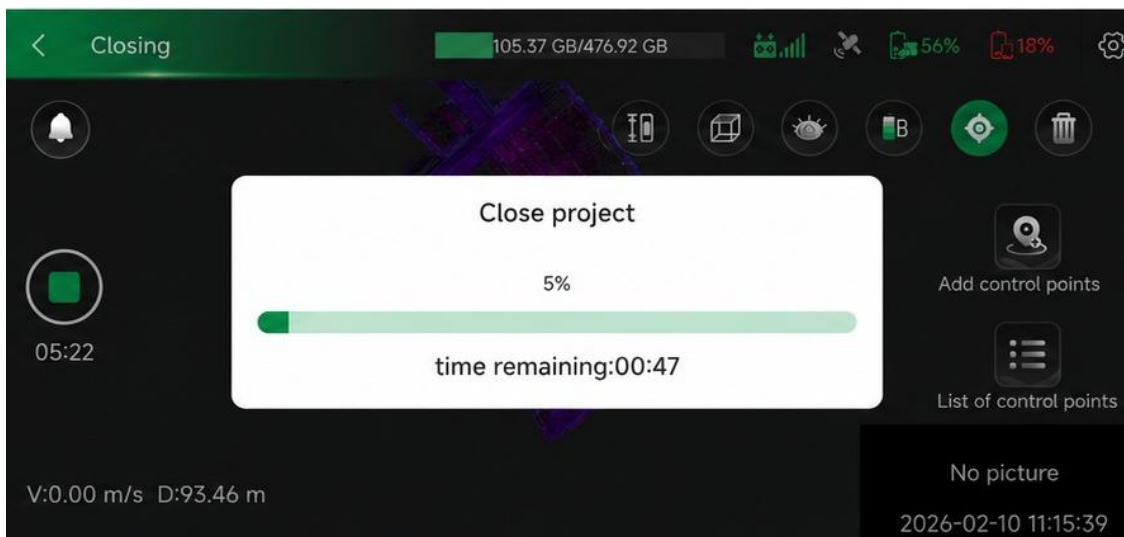
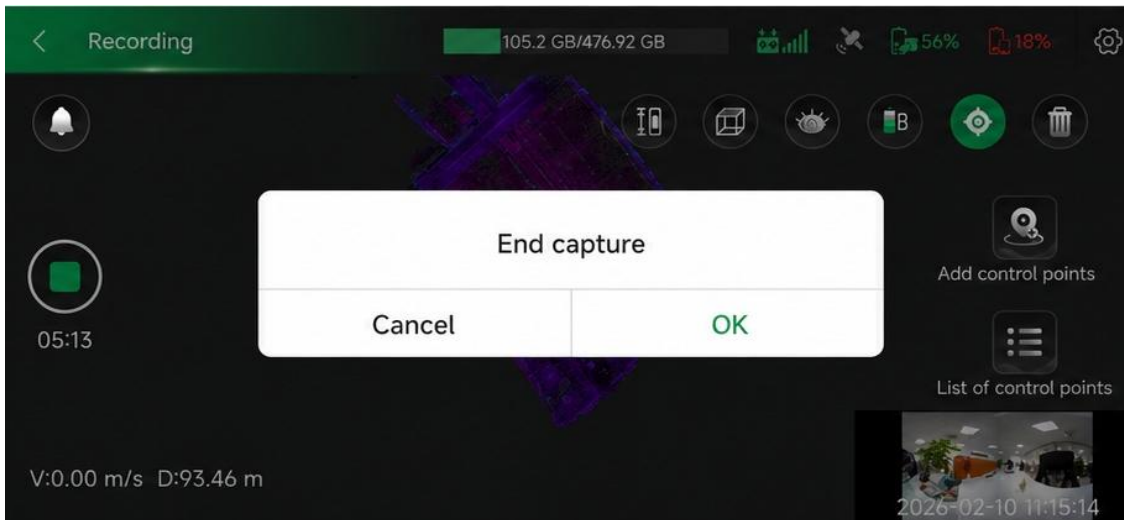

3.2.10 One-click Collection

The TrueView GO NEO supports one-click collection via the button located on the front of the battery handle.

- After the device is powered on, the indicator light stays solid blue, indicating the device is in standby mode. Press and hold the collection button at the top of the handle to start initialization. During initialization, ensure the surrounding area is clear of obstructions and the device remains stable. Once initialization is successful, the indicator light changes from solid blue to a blue-green breathing effect, indicating the device has entered scanning mode.
- To end data collection, press and hold the collection button at the top of the handle again. The indicator light will change from blue-green breathing to slow-flashing green, indicating the device is saving data. When the light changes from slow-flashing green back to solid blue, the device has finished saving and has returned to standby mode.

 **Note:** One-click collection cannot log in to the CORS account.

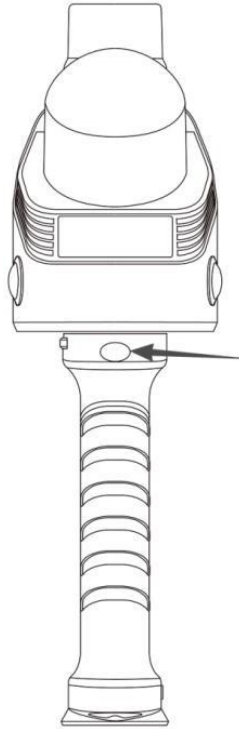

4 Collection Guide

4.1 Route Planning

Before data collection, plan the survey route in advance to ensure optimal scanning results. The fundamental principle of route planning is 'global first, then local.' Proper route planning maximizes the effectiveness of the device's correction algorithms and enhances overall data accuracy.

- Global coverage: Traverse the entire survey area using the shortest possible route to establish a stable positioning map.
- Local refinement: Perform detailed scanning using small loop closures. Progress incrementally to ensure complete coverage of the survey area.

4.2 Loop Requirement

When GNSS signals are unavailable, loop closure is required to maintain positioning accuracy. Loop closure is an important method for improving data precision. The collection route should form closed loops whenever possible.

- Ensure loop overlap is greater than 10%.
- In complex environments, close loops end-to-end and return along the same path if necessary.

4.3 Precautions for Data Acquisition

- TrueView GO NEO is a precision instrument. It is forbidden to bump or use the surface of the lidar by hand during use. Before data collection, ensure that the surface of the laser head and camera is clean and free of dirt.
- In the process of data collection, avoid fast and large-scale turning and shaking, so as not to affect the accuracy of mapping and the effect of point cloud.
- In the process of data acquisition, try to distance more than 0.5 m from the measured object to achieve good scanning effect.
- When collecting data, it is recommended to control the collection speed at 3-5km/h, and slow down the walking speed appropriately for scenes that require careful scanning or have few features.
- Try to avoid moving pedestrians or vehicles during data collection. If conditions permit, when encountering numerous moving objects, you may stand still sideways and resume scanning after the moving objects have passed.



- During scanning, avoid prolonged blocking of the device by pedestrians. When multiple personnel are working together, the operator should walk at the front.
- During data collection, point the device toward the survey area and monitor the real-time point cloud display throughout the process to avoid missing data.
- When scanning indoor rooms, it is recommended to open all room doors in advance and enter/exit sideways to ensure a good connection between indoor and outdoor data. If you cannot open the door in advance, turn around when you are close to the door, turn the instrument away from the door, open the door with your back and enter.

5 Data Processing in LP360 Land

Data copy

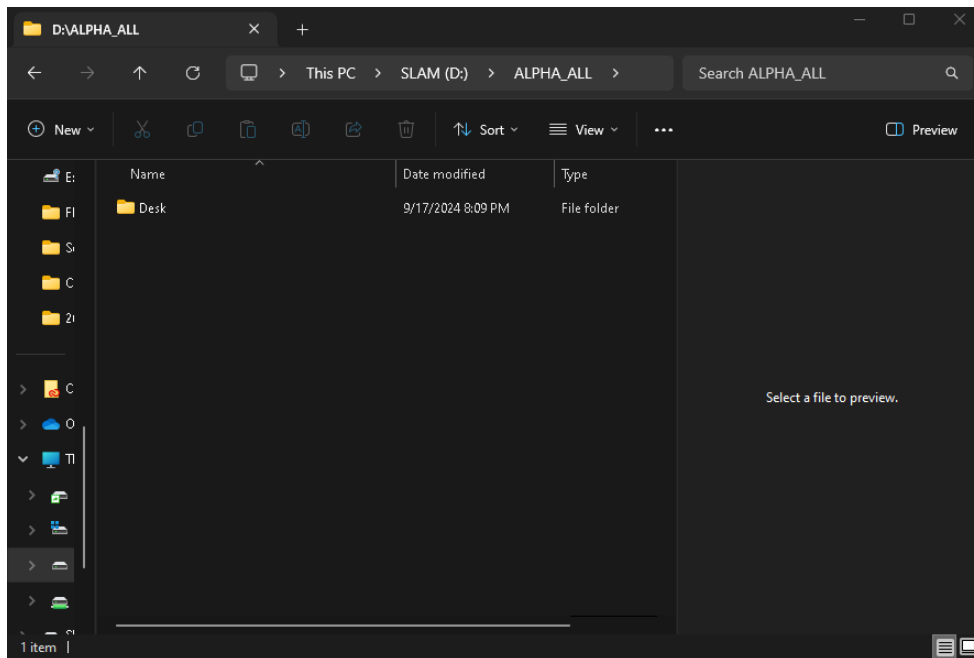
Connect the TrueView GO to a PC with a TYPE-C adapter cable, then copy the data you need.



-  **When copying data, it is necessary to turn off the device, otherwise the computer won't recognize the device disk.**
-  **Note: If the disk memory is less than 10% or cannot meet storage requirements, the user needs to free up disk space in advance.**

Open LP360 Land

1. The screenshot below will appear
2. Select “Import Raw Missions to new Project”
3. Click on “OK”

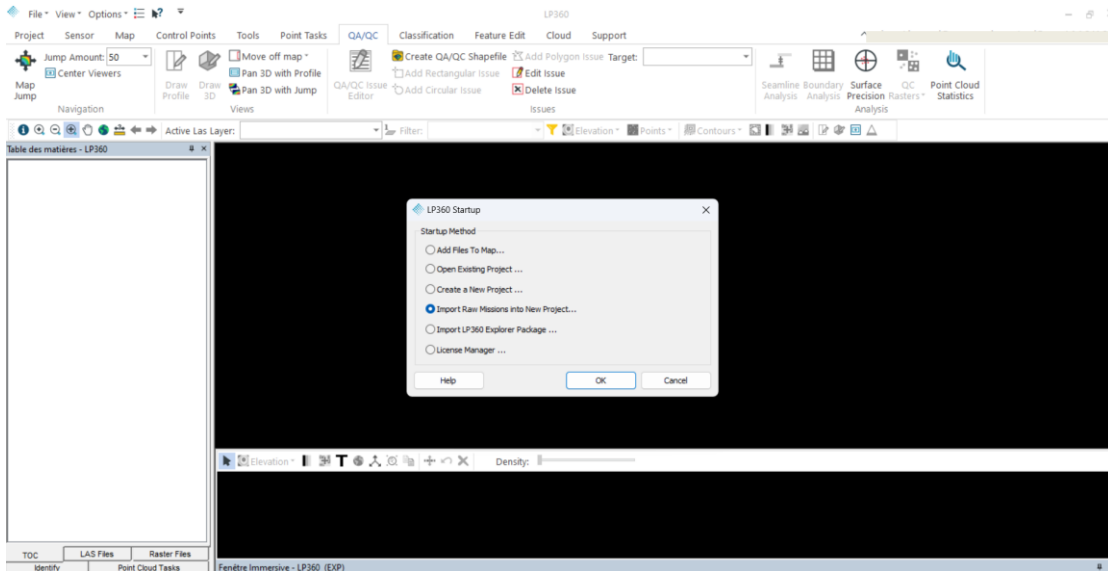

4. Select TrueView GO
5. Click “Next”

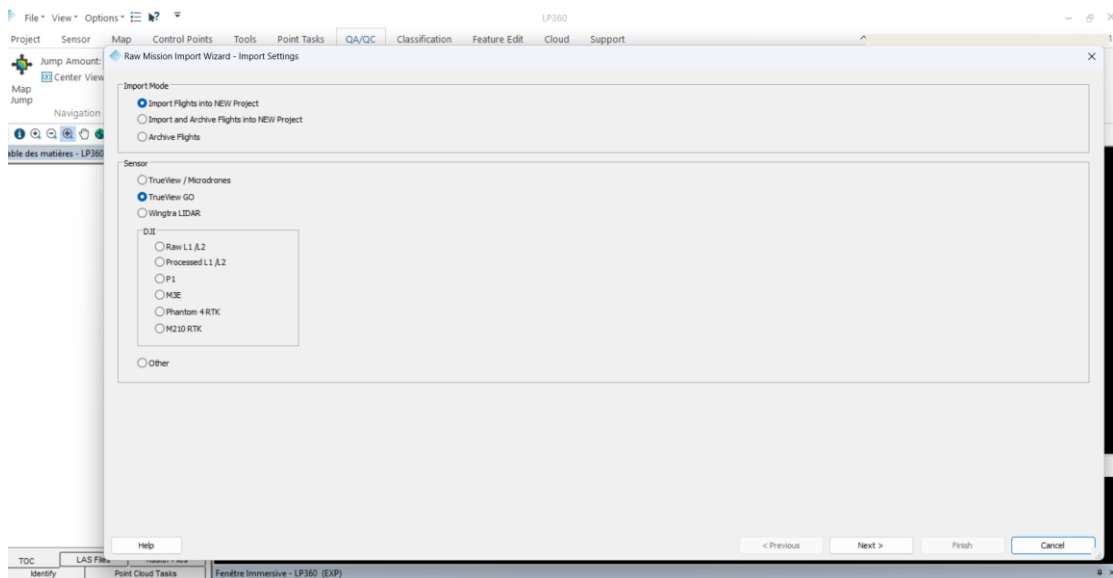

- 6. Screen will appear below
- 7. Click “Add Cycle”

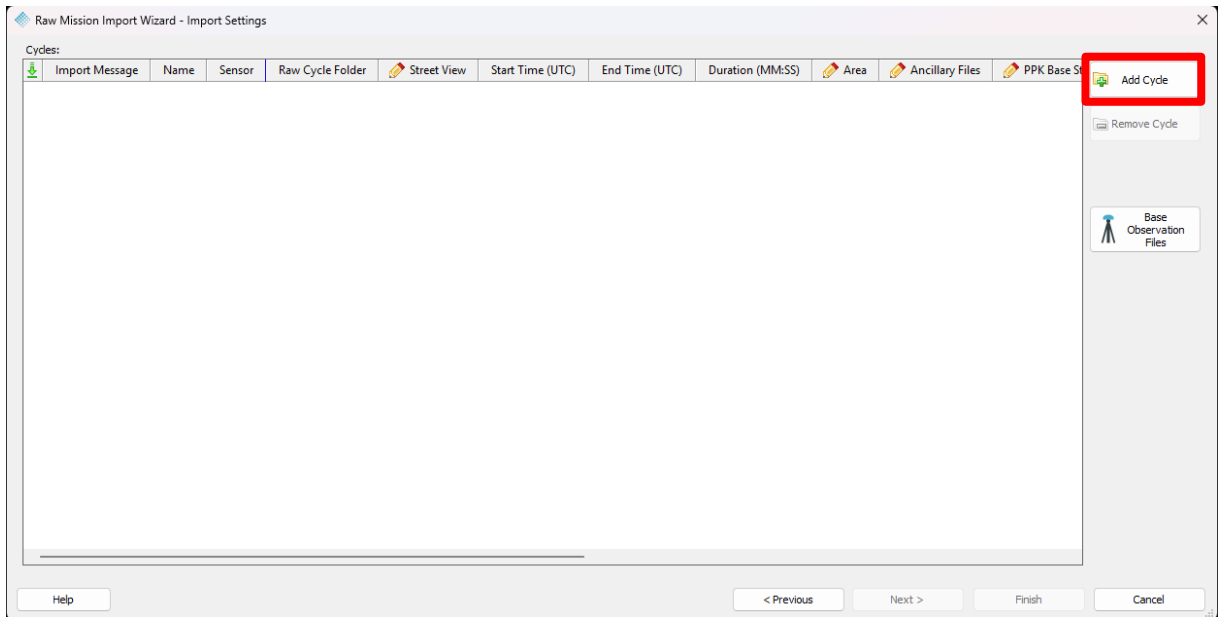

- 8. Select the file with the raw data you want to process
- 9. Click on “Select Folder”

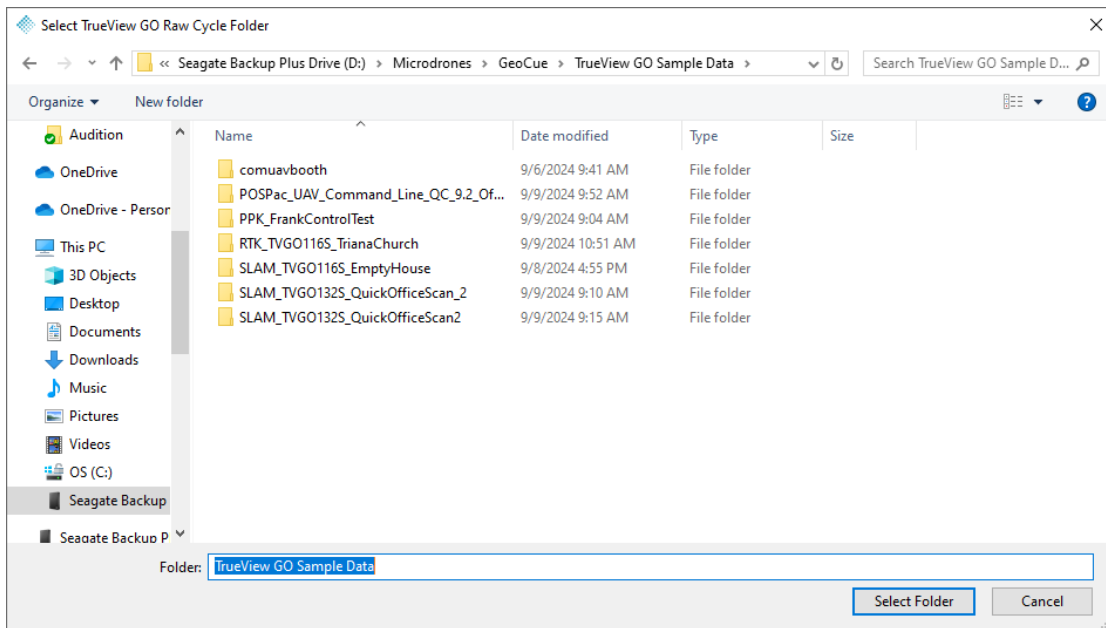

10. When the screen below appears, review the cycle information

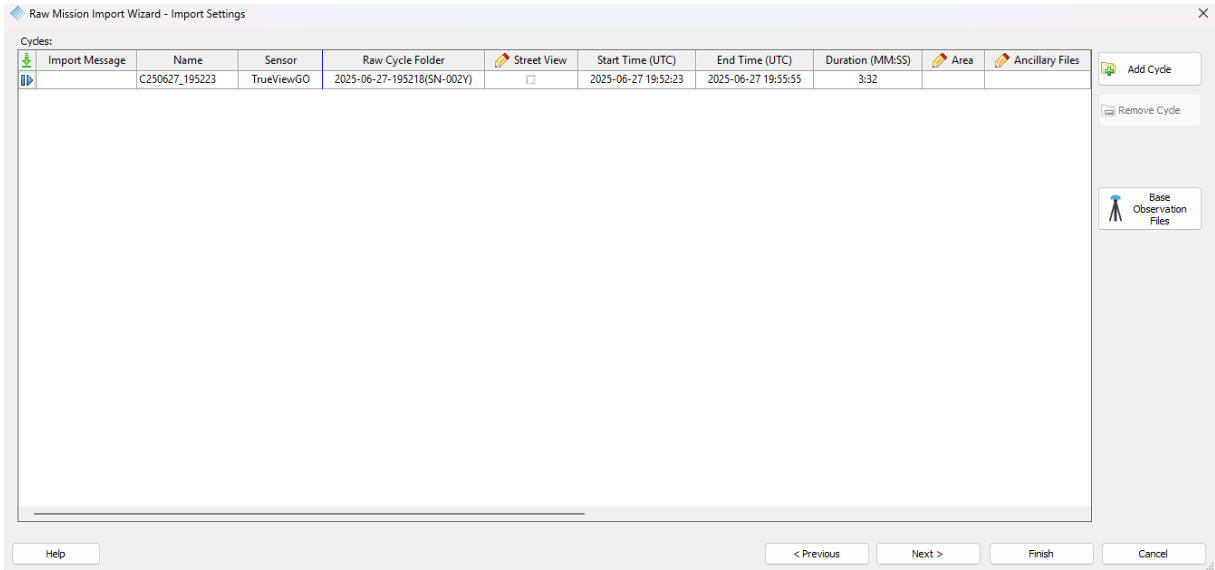

11. Click “Next”
12. Indicate the TrueView Output project name
13. Select the Project Coordinate Reference system
14. Click “Next”

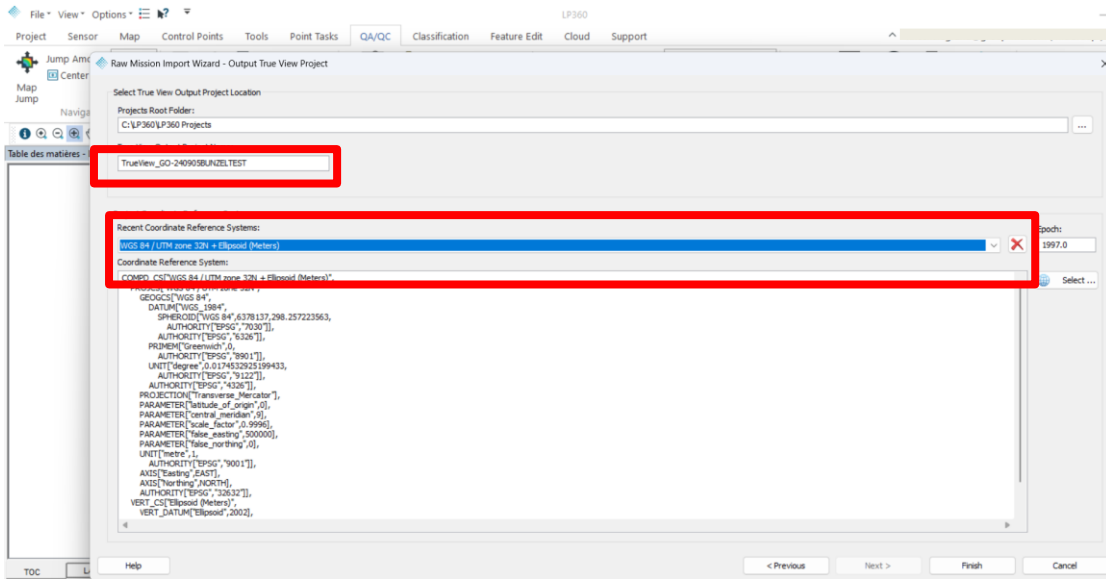

15. Data will now be imported

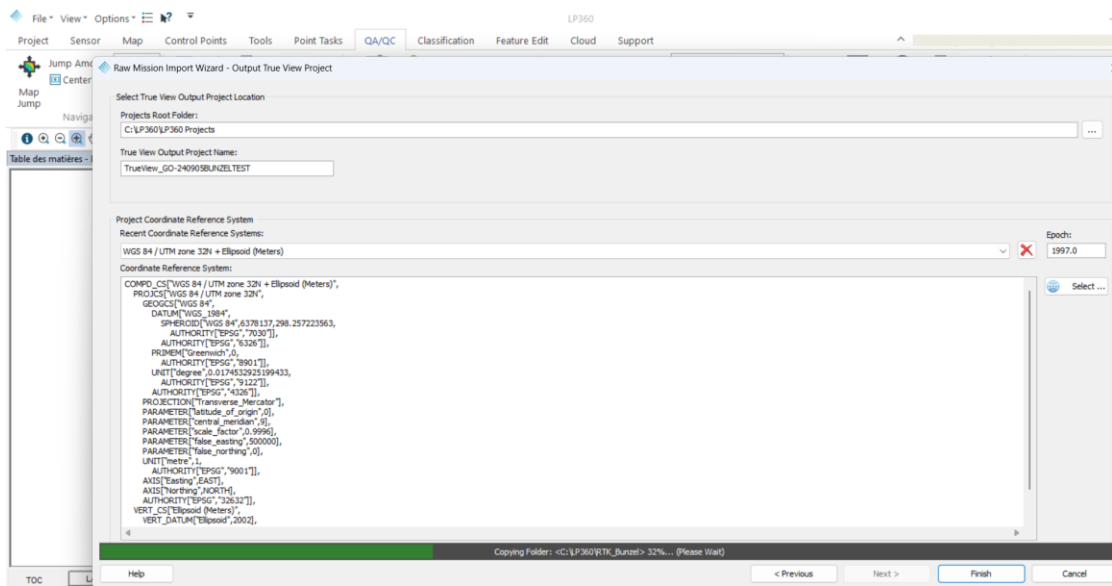

16. Once imported, click on the “Slam Processing”

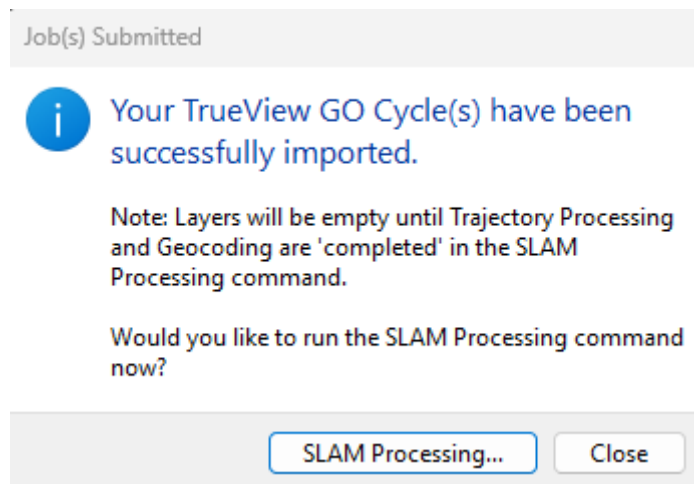

- 17. The Slam Processing screen will appear
- 18. Select your cycle and processing mode 'RTK/PPK/SLAM'.

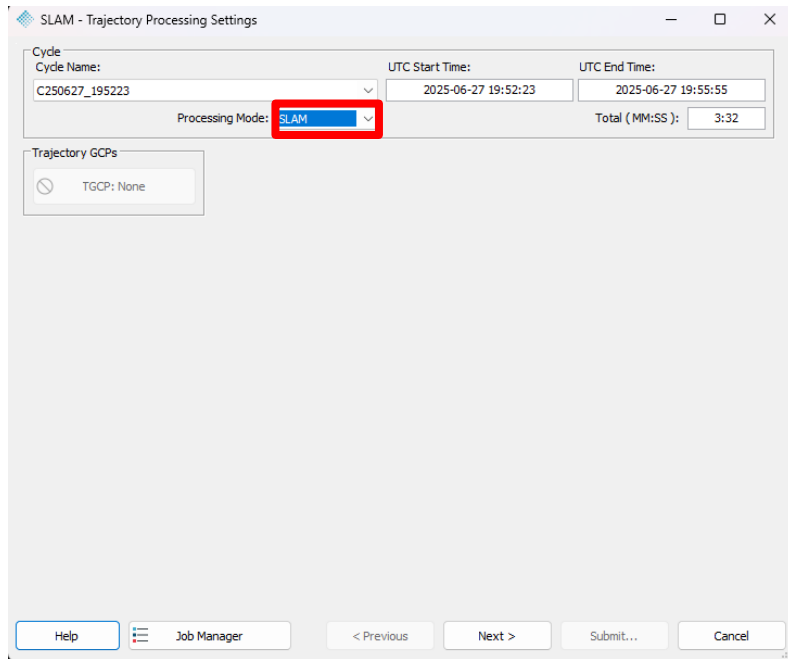

- 19. Hit Next
- 20. Select your desired geocoding settings and specify your scene type

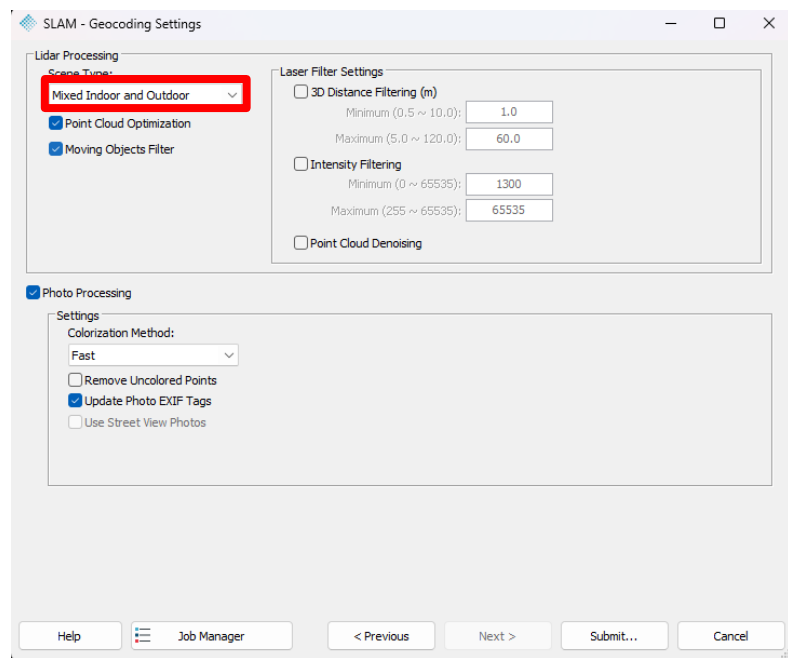

- 21. Select next and proceed to Job Manager

Job(s) Submitted

Your Processing background job has been successfully submitted.

Note: LAS, Photo and Trajectory Layers will be updated when the 'Complete' job step is performed in Job Manager.

Would you like to view the job status in Job Manager now?

[Job Manager ...](#) [Close](#)

22. Upon completion the “Ready” message will appear

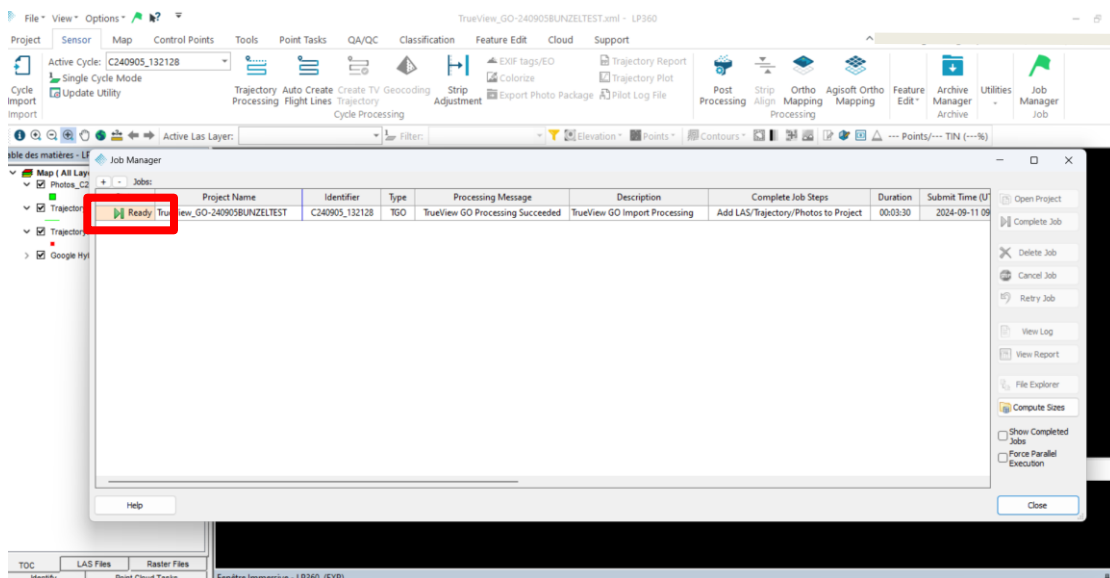

23. Select the project (you can have multicyle processing launched if you use LP360 Land Standard)

24. Click on “Complete Job”

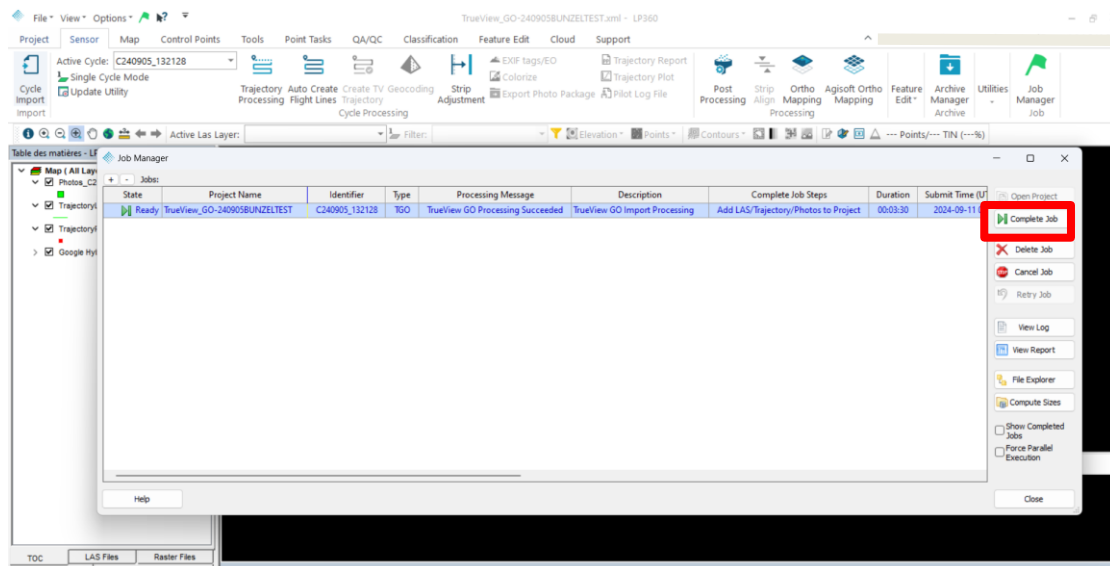

25. Click on “Yes”

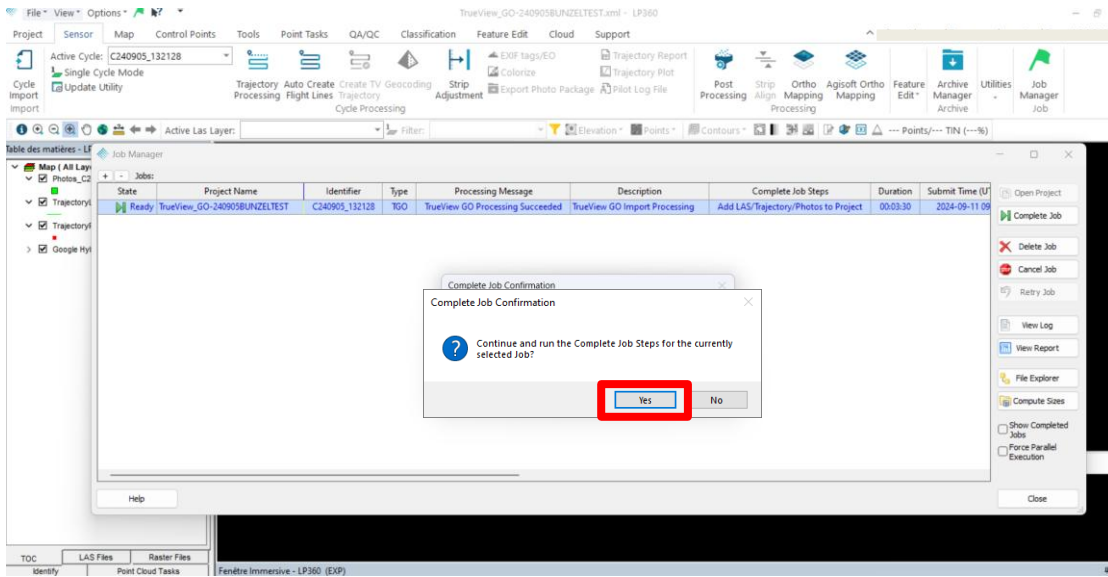

26. Your LAS file will now be ready

27. To use the Immersive View, click View and select Immersive Viewer

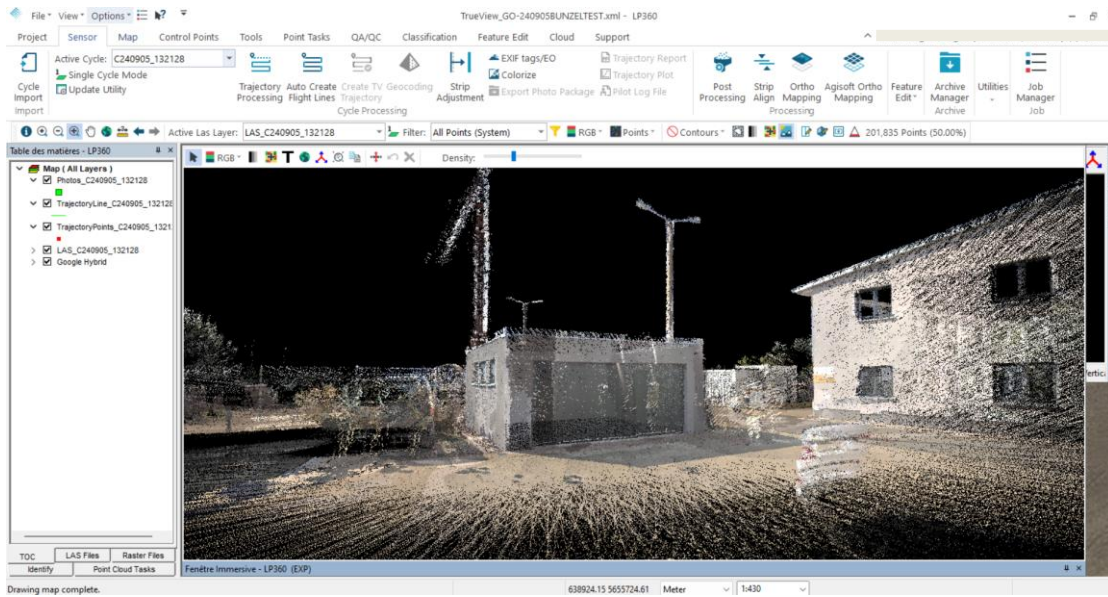

6 Frequently Asked Problems and Solutions

6.1 TrueView GO NEO Host

- The device cannot be turned on: check the battery power of the device and whether the handle battery is installed in place.
- The mobile phone cannot find the WIFI signal of the device: check whether the device is turned on.

6.2 TrueView GO APP

- TrueView GO APP is disconnected from the device during the collection process: check whether there are other APPs or other devices connected to TrueView GO NEO WIFI.
- The CORS account cannot be successfully logged into with the TrueView GO APP collection settings. Check if the tablet has a mobile network.

7 Daily Use and Precautions

7.1 Use

- ⊗ 1. For the sake of equipment safety and the possibility of more noise in point clouds, it is forbidden to use it in rainy, snowy and foggy weather, and it is forbidden to work under strong wind and dust.
- ⊗ 2. It is forbidden to expose equipment and its accessories to extreme temperatures. The operating temperature and storage temperature shall not be lower or higher than the temperature specified in the specification.
- ⊗ 3. When the product is transferred from cold to warm, water vapor may condense on some elements inside the scanner. To avoid this, it is recommended to place the scanner in a sealed plastic bag before transferring it. After the temperature of the equipment is basically the same as that of the outside world, and the condensed water evaporates, turn on the equipment again.

7.2 Daily Service Specification

The TrueView GO NEO handheld SLAM sensor is a complex and precise surveying and mapping system. In daily carrying, handling, use and storage, only through correct use and proper maintenance can the accuracy of the instrument be better guaranteed and its service life be extended. When using this TrueView GO NEO measurement system, you should pay attention to the following:

1. The user cannot disassemble the instrument by himself. If there is a failure, please contact the supplier.
2. This instruction book is a comprehensive instruction book for TrueView GO NEO measurement system. Please choose the corresponding operation method according to the specific operation. If you have any questions, please contact the support staff at GeoCue.
3. Connect the equipment strictly according to the connection method in the installation manual, check whether the screws and plug-ins of the structural parts are loose, and regularly clean the surface of the equipment, the laser window mirror and the camera lens with a cleaning kit. Follow the following steps during the cleaning process:
 - a. Choose a place with less dust and use a lens cloth to remove dust from the surface of the lidar and camera.
 - b. Use wet wipes to gently laser window mirrors and camera lenses, as well as residual dust and fingerprints in gaps.
 - c. Clean the main body of the LiDAR and camera with a wet wipe, using a soft towel if necessary. **Note:** Do not use alcohol or other corrosive liquids on non-metallic parts of the main body or camera.
4. Prevent the instrument from being strongly impacted or vibrated.

5. After the instrument is used, it should be packed in time. Before packing, it is necessary to ensure that the instrument and the instrument box are dry.
6. If the instrument needs to be operated continuously for extended periods or under special conditions such as high humidity, please consult GeoCue Support. Failures occurring under such special conditions are not covered by the product warranty.
7. Handle the equipment with care during use to avoid contamination or surface scratches. Surveyors or any personnel must not sit on the equipment or its packaging under any circumstances.

7.3 Equipment Transportation

1. The equipment is provided with a dedicated instrument box. During transportation or relocation, place the equipment inside the instrument box and secure it in position using seat belts or other restraining measures. Avoid collisions between the instrument box and the vehicle body to minimize impact and vibration.
2. During transportation, ensure that consignors or handlers avoid improper operations. Inform all personnel that the equipment is a precision instrument requiring careful handling. Clearly label the equipment as 'Fragile'.
3. For express shipping, in addition to the instrument box, an outer carton should be used. Fill the space between the instrument box and the outer carton with shock-absorbing materials such as cotton or foam.

7.4 Equipment Storage

1. When not in use, place the equipment neatly inside its instrument box. The instrument box should be placed on a table or shelf in an organized manner and **must not be stacked**.
2. The storage room should be clean, dry, and well-ventilated. Replace the desiccant in the instrument box regularly to maintain optimal humidity conditions.

GeoCue

520 6th Street Madison, AL 35756

Technical Support: 1-256-715-5091

General Inquiries: 1-256-461-8289

Email: support@GeoCue.com

Website: www.GeoCue.com